

INTENSIVE CULTURE
OF VEGETABLES
FRENCH SYSTEM



P. AQUATIAS

"Give thy CLAY to FERTILIZE the soil."—Byron.

CLAY'S

CLAY'S TRIUMPHANT CLAY'S

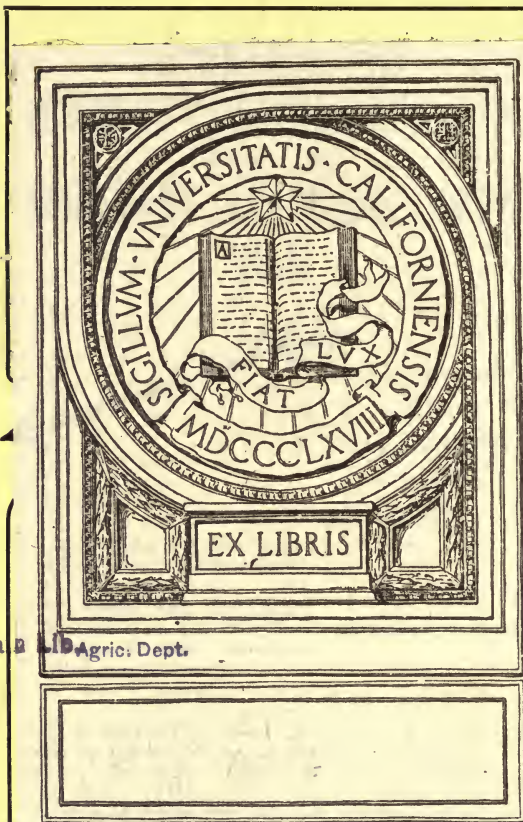

Ma B Lib Agric. Dept.

Order (except 6d. TINS).

CLAY'S SUCCESSFUL GARDENING
The Horticultural Wonderbook.

A thoroughly comprehensive, informing up-to-date publication, 276 pages, illustrated, bound in cloth. To be obtained of Seedsmen, etc., NINEPENCE NET, or Free by Post for this amount direct from the Publishers, as under.

Write for Prices of Crushed Bones, Bone Meal, and other Manures, Chemicals and Sundries.

CLAY'S FERTILIZER
LONDON
TRADE MARK.
Every TIN, BAG and SEAL bears this TRADE MARK—the only Guarantee of Genuineness

CLAY & SON,
Manure Manufacturers & Bone Crushers,
STRATFORD, LONDON, E.

The GOLDEN LINK—

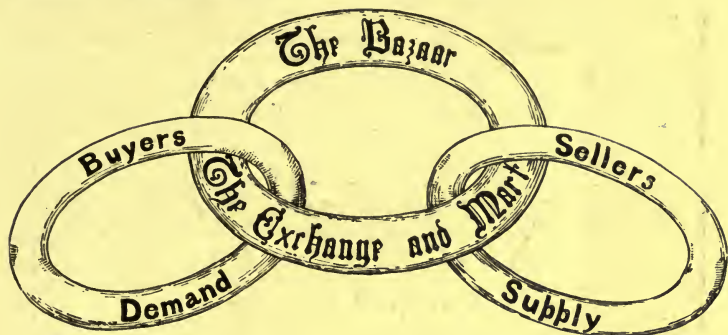

—Between BUYER and SELLER For nearly 45 Years.

For the Purchase or Sale of ANYTHING there is nothing to equal "THE BAZAAR." See for yourself the columns of classified advertisements in every issue; refer to them when you want to buy or dispose of anything; if by chance what you are wanting should not be mentioned, insert a short announcement yourself.

Advertisements of Private Property (i.e. not connected with your business); of Dogs, Poultry, Live Stock and Garden Produce bred or raised by the Advertiser, cost only 1d. for 3 words per insertion (minimum 4d.), three consecutive insertions at the price of two. Rates for Business and Semi-Business advts. on application.

You will find it a most satisfactory method of buying or selling *ANYTHING*—from a Mouse to an Elephant, a Pram. to a Motor Car, a Stamp to a Strad.

Try It Yourself. Get a Copy Yourself.

Price **2d.** everywhere; specimen copy Post
Free for 2d. in Stamps from the Offices :

BAZAAR BUILDINGS, DRURY LANE, LONDON, W.C.

Really Practical BOOKS such as

- The Small-Holders' Handbook** (post free, 3/10),
- Vegetable Culture** (post free, 1/2), **Fruit Culture** (post free, 1/2),
- Profitable Pig Breeding and Feeding** (post free, 3/10),
- Breaking and Training Dogs** (post free, 6/10),
- Greenhouse Management for Amateurs** (post free, 5/5),
- The Practical Horse-Keeper** (post free, 3/10),
- The Book of the All-Round Angler** (post free, 6/4), &c., &c.,

Are described in the Catalogue at the end of this volume; or particulars on application to the Publisher, L. UPCOTT GILL, Bazaar Buildings, Drury Lane, London, W.C.

(Unit only.)

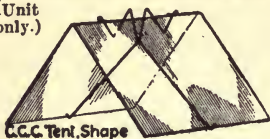

C.C.C. Tent Shape

Patent 2346/11. 702/12.

for it wastes no space whatever between the cloches, as with circular ones, and it gives plenty of room for the plants to grow.

**THE LATEST, BEST and CHEAPEST
ALL GLASS COVERING
FOR PLANTS and SEEDS IN ROWS.**

This simple device revolutionises
INTENSIVE CULTURE

≡ CHASE CONTINUOUS CLOCHE. ≡

The C.C.C. can be packed away in a very small space. The plants can be placed in rows of any length, and there is no restriction as to the intervals between them.

(Unit only.)

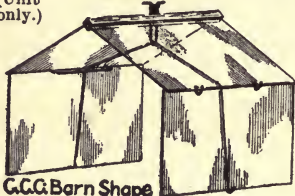

C.C.C. Barn Shape

Full details in Leaflet "C," post free.

Thousands in use already.

**THE THREE C's Co.,
67, DALE STREET,
LIVERPOOL.**

Copyright Design.

Mark Meredith, Liverpool.

OUR RELIABLE GARDEN HELPS

- "CLIMAX" LAWN SAND
- "CLIMAX" WEED KILLER
- "SIMPLICITAS"
PATENT CORD NETTING
- "ALPHOL" SOIL INSECTICIDE
& FERTILISER
- "DEMON" INSECTICIDE
- "LYTLE'S ARSENATE OF LEAD

Are used in over 130,000 Gardens and Estates throughout the Kingdom.

SENT CARRIAGE PAID ANYWHERE.
SEND TO-DAY A P.C. FOR CATALOGUE.

BOUNDARY CHEMICAL Co., Ltd.
CRANMER ST. ∴ ∴ ∴ LIVERPOOL.

FRENCH GARDENING.

CLOCHES OR BELL GLASSES, FOR INTENSIVE CULTURE.



Strongly made, no blobs, manufactured of greenish coloured glass, which does not allow the Sun to burn the lettuce or cause them to run to seed.

17" to 18" diameter ... 130/- per 100.
18/- doz. (Crates and Packing extra).

Special Rates for large quantities.

All Cloches sent at Railway Co.'s Risks.

SPECIAL "INTENSIVE CULTURE" FRAMES.

LIGHTS with Tee Iron Bars.

4ft. 5in. long by 4ft. 4in. wide, with 2in. by 2½in. Styles and Top Rails. Handle at Top and Bottom. Unglazed and unprimed	5/6 each.
Primed 1 coat, and Painted 1 coat (2 coats in all) of best guaranteed English Lead Colour, and Glazed 21oz. glass	10/- each.

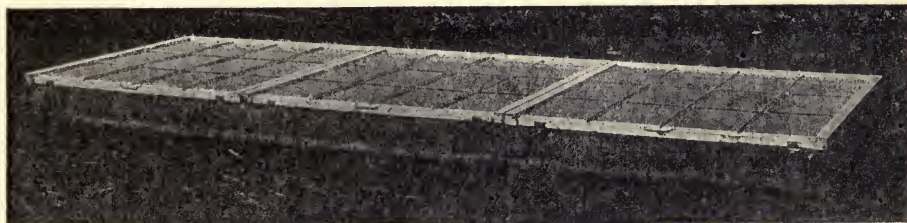

FRAMES for these Lights.

7in. high at front, 9in. at back, each frame to take 3 lights. Made of 1in. stuff, 2 cross pieces, 1½in. by 2in., with irons each end to fix over frame. Six fasteners to prevent Lights slipping off.

Prices of these Frames 10/6 each.

Sample Frame with 4ft. 5in. by 4ft. 4in. Lights with 8 iron Tee Bars, glazed and painted 40/- F.O.R. Net Cash. Packing Cases for 3-lights complete 5/- each. Packing Cases for Lights, charged and credited when returned, Carriage Paid in good condition.

SPECIAL QUOTATIONS FOR QUANTITIES.

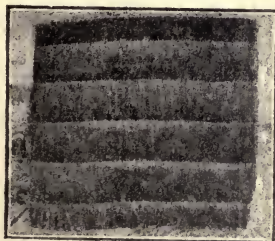

RYE STRAW MATS

Treated with Sulphate of Copper.

5 String (Hand-made), 30/- doz.

5 String (Machine-made), 24/- per doz.

SIZE 5ft. by 4ft. 8in.

EX WHARF, LONDON.

The only mat that should be used for Intensive Culture, far better than the Archangel Mats.

—Write for Booklet to—

SHEPPARD & CO.,
38, WORCESTER ROAD, EVESHAM.

INTENSIVE CULTURE OF VEGETABLES
(FRENCH SYSTEM).

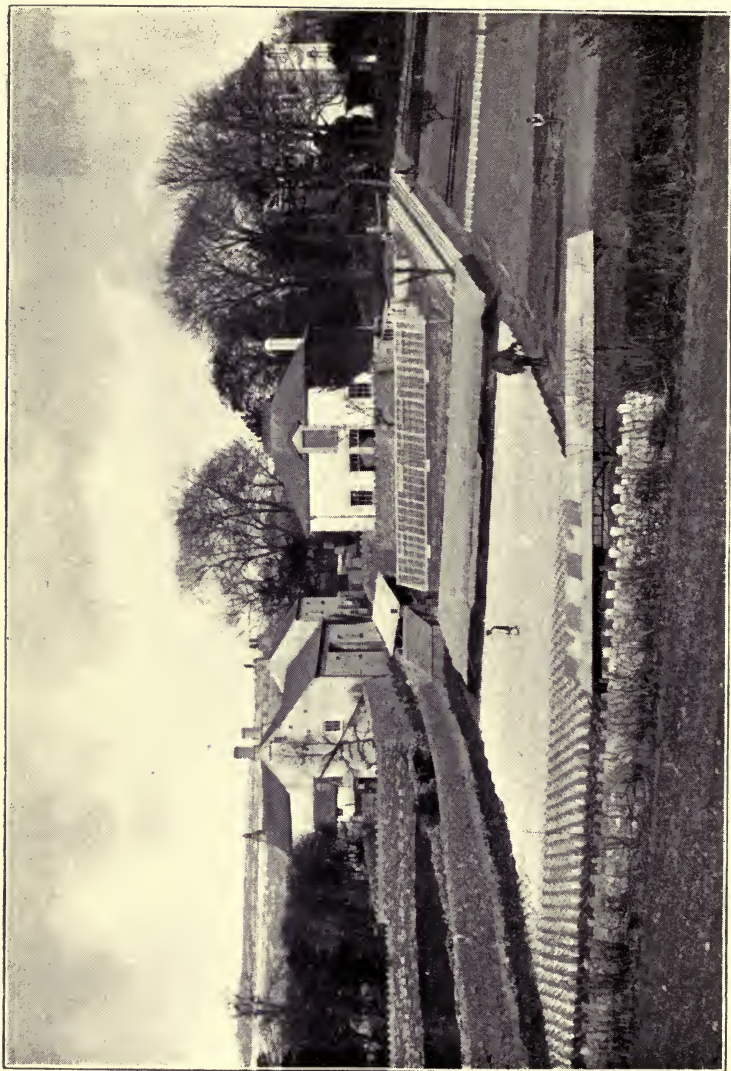

Farnorth French Garden as seen from the Road.

Intensive Culture of Vegetables on the French System.

*With a Concise Monthly Calendar of
Operations.*

BY

P. AQUATIAS

(Formerly French Gardener to A. J. Molyneux Esq.)

UNIV. OF
CALIFORNIA

ILLUSTRATED.

London :
L. UPCOTT GILL, Bazaar Buildings, Drury Lane, W.C.
1913.

Main Lib

Agric. Dept.

SB 323
A6

70 VINU
AMBONIA

CONTENTS.

CHAPTER.	PAGE.
I.—INTRODUCTORY	I
II.—EARLY HISTORY	5
III.—PRINCIPLES OF THE INTENSIVE CULTIVATION OF VEGETABLES	8
IV.—PLANNING A FRENCH GARDEN	15
V.—TOOLS AND OTHER APPLIANCES	34
VI.—CALENDAR OF OPERATIONS	48
VII.—MELON CULTIVATION	130
VIII.—CUCUMBER CULTIVATION	146
IX.—MUSHROOMS	151
X.—SEED-SAVING	168
XI.—VEGETABLE AND ANIMAL PESTS	177
INDEX	187

LIST OF PLATES.

FARNORTH FRENCH GARDEN	<i>Frontispiece</i>
WATERING WITH CANS	<i>..facing p. 36</i>
PREPARING MUSHROOM SPAWN	,, 154
MUSHROOM CULTURE—ARRANGING MANURE				,, 160
MUSHROOM CULTURE—PLANTING THE SPAWN				,, 162
MUSHROOM CULTURE—WATERING	,, 164

Intensive Culture of Vegetables.

CHAPTER I.

Introductory.

Les récoltes se succèdent de six en six semaines; et après chacune, l'homme retrouve sa terre aussi vaillante et aussi docile qu'auparavant. Parce qu'il lui est dévoué, il la possède comme personne ne la posséda jamais, comme jamais amant ne posséda sa maîtresse.—(La Cité Chinoise—G. Eng. Simon.)

“Crops succeed one another every six weeks; and after each the cultivator finds his soil as productive and as workable as before. Because he is devoted to it, he esteems it as no one ever esteemed it before, and as no gallant has ever esteemed his lady love.”

ONCE the meaning of this quotation is fully understood, it will give a fair idea of the spirit that should dominate the enthusiast in the intensive culture of vegetables. The cultivator must be devoted to and interested in his work and really love the land, the mother of all wealth and production and the most important asset at his disposal. The aim of this system is not so much what a crop will bring or what profit is to be derived, as to obtain from the land all

that God wanted us to get from it for our welfare, livelihood, and happiness.

In this mercenary age, the love of gain dominates all our actions. We are always calculating on the highest returns for the least exertion, and we are often led to believe that practice of a method is accompanied by big profit. Fortunately we find our mistake at an early date, and as the corollary of this love of gain has forced us to specialize in a particular branch of production if we desire to compete successfully.

We all have a natural tendency towards gardening that manifests itself from the earliest age, but it can only be adopted as a profession when we have trained ourselves in one of its numerous branches. The intensive culture of vegetables, to be successful, must be treated as a speciality; it is such a complex system of cost, labour, and brain that to understand it thoroughly it must be judged in its entirety. Everything is weighed, calculated, timed, and checked; every crop has a cycle of growth to follow and it must work as a piece of ingenious mechanism for the welfare of the others that succeed it. Man has everything under his thumb; but it is only experience and full knowledge of his subject that will enable him to obtain favourable results.

George Ville, the initiator of the use of chemicals, has proved that where the land is well treated it can produce three times more than is necessary to feed all those dependent upon it. He has also demonstrated that plants can obtain their nourishment from another medium than the soil. What he has shown is possible with the help of chemicals the intensive culture of vegetables has done by means of decayed manure as

the medium of growth and source of nutrition. The grower does not trouble whether a crop will thrive, because it is a positive fact he has given in the winter or early spring all that was necessary, therefore he knows he cannot well be disappointed; and should a crop not come up to expectation he can attribute it with just cause to faulty cultivation or to adverse weather.

The initial cost of the system under notice may appear extraordinary, but it compares fairly well with the cost of the establishment of a nursery of similar area. Moreover, we must bear in mind that the system is practised in a country where all raw material is heavily taxed, and where coal is scarce and expensive. Lights and bell-glasses have been found more economical than heated structures, and are used for all kinds of crops besides vegetables.

Manure, water, and labour, which constitute the backbone of intensive culture, are easily obtainable near populous centres—the most propitious places in which to start such an undertaking. We may emphasize this economic fact, that the longer the system is practised on the same ground the better are the results to be obtained; the elements in use increase both in quantity and fertility, while labour decreases owing to greater facility in the working operations, and all the appliances are easily constructed and kept in repair. English produce, in regard to quality and earliness has been equal to that grown in France, and especially when the grower has been judicious in his selection and grading of goods, and by having a constant succession till the bulk arrives from the fields. We are convinced that this system can be successfully practised when undertaken on a strict business basis.

Unfortunately there have been failures, but these were not due to the system but rather to the position of the gardens or their management. Horticulture in all its branches suffers from the excessive railway rates and lack of distributing centres, entailing extra charges for commission, handlings, and transit, while if we add allowance for waste, no one has a sufficient profit and the consumer pays excessive price.

We may be remonstrated with for not giving even approximate returns as a guide to beginners. We have, however, tried through this little work to be integral and to give an impartial idea of this system. We could not, therefore, give returns, as these would have been misleading. The demand governs the supply and no grower has control over it; the weather, the standard of goods, and the locality are a few of the points to consider when fixing a price for every class of produce. The price obtained in past seasons is no guarantee as to the future; and, with so many points to bear in mind, we thought it advisable to refrain from introducing figures which for practical purposes would be entirely useless.

The idea of writing this book was conceived many years ago, as a slight recognition to those by whom we were instructed in the craft. At the same time, should it be useful to others it will more than have accomplished its purpose.

CHAPTER II.

Early History.

THE intensive culture of vegetables, so largely practised in France, and to a small extent in this country, differs materially from the ordinary cultivation; crops occupy the ground during the whole year, and are also concurrently grown together in the same space. This system of cultivation has occupied a prominent place in France for several centuries, as is attested by its literature. The idea of obtaining early produce with the help of glass is mentioned in "Le Theatre d'Agriculture et Menage des Champs," by Oliver de Serres (1539-1619); but the originator of forcing vegetables on more or less scientific lines was La Quintime (1620-1688), Head Gardener of Louis XIV., who had to supply the table of his august master with delicacies all the year round. His methods and ideas were soon adopted by the numerous market-gardeners (*marâchers*) who were established on the outskirts of Paris—at Vaugirard, Grenelle, and Passy—where they flourished until the builders gradually forced them to move further afield.

Before the French Revolution these *marâchers* were all affiliated to a Guild, and important questions relative to their trade were constantly discussed. One of their resolutions was to condemn the use of cow- and pig-manure as being unhealthy and quite unsuitable for their work—a conclusion as wise as it was

practical. Very little is known as to their trade during the French Revolution except through the authors of fiction, who frequently introduce the horse and cart of a market gardener to further the escape of their heroine. In 1820, however, these market-gardeners began the forcing of Cos Lettuce under cloches which were altered in diameter and height to suit the methods employed. The composition of the glass was also experimented upon till the favourable greenish tint was obtained.

Previous to the Franco-German War the *maraîchers* were exceedingly prosperous, and not only grew edible vegetables and fruits, but they were also renowned for their culture of annuals in pots, especially Stocks. Some of the more skilled gardeners were, moreover, able to differentiate in the young state the double from the single plants, and went from one garden to another eliminating the latter before the final potting in 48's. During the siege of Paris (1870-1871) French market-gardeners used all kinds of cunning stratagems in their endeavour to cross the lines and to bring vegetables into the city; when they were successful the prices they obtained amply repaid them for the risks they ran.

Though the competition to obtain the earliest and best produce had always been keen between the *maraîchers*, and had been a great incentive for them to reach that pitch of perfection we all admire, it was originally confined to a radius of twenty miles from Paris; but the special tariff made by the French railway companies opened the market to their competitors from every corner of France and Algeria. This competition compelled them to abandon certain cultures and to alter their material. Though the

principles of cultivation were not altered then, a labour-saving system was introduced, for we find that from 1880 they employed first animal and then steam power in watering—an operation which previously was done by hand. They, however, had the advantage of their provincial colleagues as to skilled help in every branch of their trade. Though this competition was keenly felt on the Paris market, it opened new outlets for their produce in the different Continental capitals, even as far as St. Petersburg and Lisbon. They also specialised in the culture of vegetables and fruits which do not travel well—Lettuces, Turnips, Radishes, Melons, &c.

This branch of gardening has always remained independent of any other class of horticulture, and for many years syndicates for the employers as well as for the employees have been formed. Most of the gardens where this system is practised are worked by the members of the same family, or with the help of one or two hands while the proprietor's children are too young to do the necessary work. Though women never assist in the actual cultivation of the crops, they have the entire management of the packing, dispatching, and selling of the produce. In this department they excel in quickness and neatness, as can be seen at the Halles Centrales in Paris every morning, where they stand with their wares.

CHAPTER III.

Principles of the Intensive Cultivation of Vegetables.

THE combined experience of generations of *maraîchers* in the districts around Paris has taught them strictly to adhere to certain well-defined principles in the practice of their craft. Improvements have been made both in the material used and in the strains of seed grown, yet the natural laws of vegetation have been closely followed. A study of the principles of this system will give the novice a fair idea of the working of a French garden, but the actual details of cultivation will be found very similar to those associated with other systems of gardening.

Intensive culture on a more or less extensive scale must, save in exceptional circumstances, be treated as a business or run on business lines. Amateurs and private gardeners can learn to supply their own requirements by this system, but to fully appreciate its possibilities it must be worked as a commercial business.

The principles of the intensive cultivation of vegetables are :—

- 1st: Uniformity.
- 2nd: Constant and even growth.
- 3rd: The working with and assisting of Nature.
- 4th: Intercropping.

Uniformity.

It is absolutely necessary in face of the keen competition in the open market to have uniformity in appliances, spaces cultivated, and manual labour. This is very obvious on paying a visit to the gardens surrounding Paris, where intensive culture is most largely practised. All lights, frames, cloches, and mats are uniform in size and shape, and this has been the result of years of experience put into practice, and makers now manufacture the various articles to meet in every respect the requirements of the gardeners.

The main idea is to be able to interchange the appliances from any one part of the garden to any other where needed, and this is also the reason why the ground is laid out according to the measurements given in the special section on page 19. Uniformity of material in size and weight means expediency and simplicity in labour, and saves unnecessary mental work in deciding its position on the ground. Uniformity is also noticeable in the width of the beds in the open; they are always either 4ft. 6in. in the case of single beds (the width of one light) or 10ft., which is equal to two single beds and one path.

The system of planting either in the open or under glass is also uniform, allowance only being made for the necessary head-room of the plants. The aim of the growers has been to simplify the heavy manual work, so that they can have more time at command and utilise all their capacity and experience in attending to the numerous details necessary for the good cultivation of the crops. The work has been brought to such a methodical and uniform standard that good

growers know the proper time for each operation and the number of plants requisite to fill any allotted space. They always work with an idea—one which allows them to obtain what to an outsider would appear an enormous quantity of produce without waste.

Uniformity of material and management also allows them, when necessity occurs, to undertake important work—such as the making of the hotbeds in the spring, or the establishment of the winter quarter for the Lettuces—in a very short time, when the weather is not, as is often the case, favourable to these operations. Uniformity also predominates in preparing and packing the produce for sale, as a visit to the Paris central markets will prove. The advantages of uniformity here are manifest, for the salesmen and the buyers alike know the size of the bunches and the number in each package beforehand.

Constant and Even Growth.

An important point in the intensive culture of vegetables is never to allow a plant to stop growing. From the time the seed is put into the soil till the plant is marketed the French grower keeps it constantly moving by giving it all that is necessary for its welfare. By this method a plant is got ready for market in the shortest possible period, and therefore time is gained and money saved. Further, by such means an even growth is also obtained. A whole batch of plants can therefore be marketed within a few days, thus enabling the ground to be occupied by another crop without loss of time.

When a plant stands idle the cells and other vessels harden and are unable to fulfil their important func-

tions; the rootlets which absorb the necessary nourishment soon perish. When the plant is brought into a condition more favourable to growth, it has to form new rootlets, which, according to the situation of the plant, takes more or less time, and the result is that unevenness of growth so noticeable in many gardens. This is what a French gardener avoids at all costs. He grows different plants together; therefore every subject must follow the course of its natural vegetation, in order that it may be cleared off the ground in time to make room for the plants that take longer to grow or that require more room. This principle explains the care taken in regard to strains of varieties grown under the system, the reasons for the special dates for sowing, and the uniformity of the work.

The little time for growth which is allowed to each plant amply demonstrates the thorough knowledge and practice of French gardening. All the plants are sown at the last possible moment, even when early production is aimed at. To obtain such result a grower must work with certainty and confidence, as a failure in the germination of seeds, or at an early stage of growth, would spoil the crop. As the success of one crop often depends on the good growth of another, the importance of even and constant vegetation of each batch of plants under cultivation may be readily understood.

Working With and Assisting Nature.

To force a plant is to cultivate it at a different season from that at which it would naturally grow, or to work against Nature. French gardening, however, does not tend to force a plant, but to give it what it

requires to start or continue its cycle of growth when the weather would otherwise impede it—in other words, to work with and assist Nature.

With the quick transit of goods and the perfect methods of refrigeration now in use, it is possible to obtain from more genial climes fruit, flowers, and vegetables all the year round. It is therefore very risky to force a plant, as one has not merely to take into consideration the extra cost of production, but also the increase of failure in the culture for a problematic and often unremunerative result. It would also be departing from the principles of modern intensive culture to attempt to grow vegetables at an unnatural time, so far as growth is concerned, as the system aims at quality and quantity of produce: the earliness is obtained by following the numerous details of cultivation and by making the best of the material at disposal.

The busiest time in a French garden is during the spring. At that period the Vegetable, like the Animal Kingdom, is under the influence, as it were, of a new life: it is Nature's great reproductive season. There is then produced a certain amount of vital energy unknown at another time of the year. Unfortunately, this force is wasted in many systems of culture owing to climatic conditions. Brisk changes of temperature, storm, cold, rain, and sometimes snow, impede the course of this new life. The French gardener simply helps this vital energy to work to its utmost capacity by giving to the plants heat or shelter as necessity requires. Working with plants in good health, full of vitality, he cannot but succeed if he knows on the one hand what is lacking or on the other what is preponderant.

Intercropping.

Much has been said about the French system of intercropping. The correct method is the key to certain success. To understand it in its entirety one must have first, a complete knowledge of every strain of vegetable; secondly, the type of every variety; thirdly, the time required for a crop from the final planting till it comes to maturity; fourthly, the time of the year which is most suitable for the cultivation of a variety; and fifthly, the best medium for its growth either in hotbeds, in cold frames, or in the open ground.

There must be no hurry where the correct method of intercropping is pursued. A plant must be ready at a given time and have reached a certain stage of growth, or the crop growing with the unprepared one would soon get the upper hand and spoil it. It may even be necessary to give up an intercrop if this does not keep up to the standard of its growth, in order to save the main crop, which would soon deteriorate if the former were left longer than was good for the latter.

There are a few standard rules for intercropping which are followed by nearly every French gardener. Though they may vary as regards the selection of plants to meet local conditions, their guiding principles are the same. First, you plant or sow a crop which can be ready and cleared off the ground before the main crop requires the room to itself—*e.g.*, Radishes or Lettuces as intercrop and Carrots as main crop. Secondly, plants are sometimes left to grow until they reach a certain stage before the main crop is set in, because the latter would require the room before the former is ready; Endive, for example, as an intercrop, is set three weeks before the Cauliflower

(main crop) is planted in the same bed. Thirdly, a batch of plants is grown as a main crop till the course of growth is practically complete before planting the intercrop, which is set in time to get established before the main crop is cleared off the ground. Take Melons; these as a main crop are grown for from eight to ten weeks before Cauliflowers (intercrop) are inserted.

Correct intercropping is a constant source of work, as the time allotted to each plant to reach a certain stage of growth is strictly limited. The growers rely mainly on the strain and, above all, on the quality of the seeds. This explains the difficulty encountered in getting the special strains used in this system, as most gardeners prefer, when possible, to raise their own seeds from parents selected according to class of soil and the special type of plants required for future operations. A chapter is devoted to the consideration of this important subject.

CHAPTER IV.

Planning a French Garden.

As we have tried to emphasize, this system of cultivation must be conducted on essentially business lines, for it is only on this method that it is possible to ensure a large quantity of produce and to maintain the excellence of the crops. Not only must the grower bear carefully in mind the marketing of the produce, but also, and mainly, the cost of production, as the financial returns are always, as in any other system, more or less problematical, being governed in fact by the uncontrollable laws of supply and demand.

The initial outlay of capital is sufficient to prove to a prospective French gardener that to do himself justice and those dependent upon him he must be certain that he can not only manage the concern once begun, but prove himself a good organiser in the establishing of his garden. The first point is that the owner must give up his whole time to the concern. He must also start on a scale that will enable him to utilise his ground and to find a constant and remunerative occupation. There must, however, be no exaggeration in regard to this detail, as the aim of the cultivator is to obtain the full productiveness from the ground; therefore to have more material than he can accommodate would be a dead loss.

Experience has taught the French grower that two acres are amply sufficient to obtain the maximum of produce. A quarter of this space is covered with glass at one season; another quarter is in readiness to receive the material when the season's work is done,

to start another; whilst the other half is left to outdoor crops, which are a necessary complement to the economical working of the glass department. It would be a mistake to think that a large staff allows an owner to start or work a French garden on a bigger scale, and to obtain therefrom a return in proportion. To attempt alterations of the methods (unless it is done progressively) is to run great risk, as it tends to destroy the homogeneity of management; it also means the abandonment of the numerous details which make for the success of the system. The quality of the produce would probably be inferior owing to the enormous quantity to be handled in a short time. Again, the increase of labour and material would not always work profitably together owing to the slackness of occupation at certain times and too much material being idle at others.

If we take, for example, the watering, which must be done in summer before 10 a.m. at the latest, we have, say, sixty melon-beds, or 1000 lights. These will require 3galls. of water each, or 3000galls. to be used within three hours, which will occupy at least four men. The irrigation will therefore be established on a basis for employing four men, without making allowances for the other crops. At that period there will also be ample packing. The produce to be in good travelling order must be gathered in the morning, and will mean extra labour in hand. By having too much material the responsible manager will not be able to attend to everything, and inferior crops will result.

Around Paris, where skilled labour is always obtainable, the standard number of lights is 600, and of cloches 3000. Generally a man starts with half that number until his ground gets in good condition,

when he brings his material up to the standard. In a well organised and conveniently situated business the number is brought up to 1000 lights and 4000 to 5000 cloches; but we know of no instance where these figures have been exceeded.

The most economical way of starting is to have the lights painted and glazed and the frames made on the premises, as the carriage of the ready-made articles always entails heavier expenses and more handling, to say nothing of the possibility of breakages. It also ensures having all the small appliances introduced at the very place where they are wanted and having them uniform in every respect.

The cost of the establishment of such a garden is approximately as follows:—

PURCHASE OF LAND AND NECESSARY OUTFIT.

300 Lights as described at 8/-	£120	0	0
100 Frames with bars, clips, at 8/-	40	0	0
2000 Cloches at £5 10s. per 100	110	0	0
550 Mats at £7 per 100	38	10	0
Irrigation, Company's Water (Private Supply about £120)	60	0	0
Tools	12	0	0
Horse and Cart	50	0	0
Shed and Stables	100	0	0
Land (two acres)	150	0	0
				<hr/>		
				£680	10	0

WORKING EXPENSES.

400 Tons of Horse Manure at 6/-	£120	0	0
Seeds	10	0	0
Keep of Horse yearly	25	0	0
Labour Bill (approximate)	150	0	0
Interest on Sinking Capital, £680 at 5 per cent.				33	15	0
Wear and Tear of Material at 5 per cent.				28	15	0
Rates and Taxes, roughly	10	0	0
Water Rate (Company's water)	20	0	0
				<hr/>		
				£397	10	0
						C

As the figures show—and they are obtained from different sources—the outlay is roughly £1000 for the first year.

Choosing a Site.

When selecting a piece of ground for a French garden there are several points to be borne in mind. It must be conveniently situated, where manure can be had at little expense for carting, and where an ample supply of water can be obtained. There must be a ready market and railway station near—in fact, every facility for saving trouble and expense must exist. The cost of a piece of ground near any increasing town will naturally be greater than it will be for a piece in the country far from a building area; but even after paying a high price for it there is the certainty of being on the right side in the saving of what can be classed as current expenses. The ground should be naturally sheltered from the north-east especially, as the cold blasts from this quarter are very injurious when one is nursing young and tender plants. A good road for carting to and from a station is almost indispensable, as so much work has to be carried on during the wet months of the year.

The plot chosen should be nearly rectangular, or at any rate of such a shape as will admit of one getting a straight line to work from without wasting too much ground in the corners, although these may be utilised. The details of this, however, will be found under the heading “Uniformity.” The garden should be as level as possible, so as to lighten the labour in carrying to and fro, and should there be any slope, it should be southwards. Light loamy soil is preferable, though the quality of the land, provided it is arable,

is of little importance, as the decayed manure from the old beds supplies any deficiency in this respect. Low, damp places and foggy districts must always be avoided or great difficulties will have to be surmounted, and even impossibilities would have to be faced.

Preparation of the Ground.

After selecting the site, the next thing of importance is to find a straight line upon which to base all future measurements and to consider the following: The line must be chosen according to the situation of the garden; the access from the road; the position of the buildings, &c. The ground should be divided into parallelograms 70ft. wide, and it is extremely important that these are made at right angles to the approaches of the garden, even if in doing so their position is thrown eastwards or westwards, though, of course, facing south is the best. With ground of irregular shape all irregularities are thrown on the "Costieres," or beds against boundaries. The width of these beds also varies up to 30ft. if the width of the area leaves a fraction of a full size division (70ft.) on the east or west sides.

Besides the paths between each division (the width of the path is included in the width of 70ft.), there should be one permanent path at the top and one at the bottom of the garden, and when the length of these divisions exceeds 150ft. a central path will also be needed. The position of the latter always varies, and is generally made up at the end of the hotbeds.

When the ground has been marked out a general level must be found, and if the ground is on the slope it must be even and the slope not too excessive.

If the ground is hollow anywhere, the soil from the path will often be sufficient to supply the deficiency.

The next operation is instilling the irrigation, which the Plan of the Tiptree Garden (Fig. 1) shows. A row of pipes should be laid on the boundaries of each division, 12in. to 14in. deep, and a stop-valve fixed at the end of each row, by means of which the pipes may be emptied during the winter. The pipes should only be sunk sufficiently deep to be out of reach of the tools.

The digging and the divisions of the ground should next be taken in hand. The turf is generally dug in, as it decays very rapidly and forms excellent nourishment for the prospective crops. In new ground it may be necessary to spread gas-lime or Vaporite to destroy soil insects and other pests which are otherwise sure to prove troublesome. The place for hot-beds will not require deep digging, but it must be very carefully levelled.

The ground intended for immediate cropping must be heavily manured with ordinary farm manure. The paths must be well constructed, as the heavy work takes place during the winter. They may be built with different material, according to the locality—stones, clinkers, and gravel, however, always form a good and hard surface for wheeling, &c. The width of the paths should never exceed 5ft., and we advise, if procurable, the employment of old railway-sleepers, used two abreast in the centre of the paths. They are cheap, lasting, and always clean. For a garden of two acres the cost of the paths without the laying would rarely exceed £10.

The place intended for the stacking of the manure must be accessible from the road, and as close as

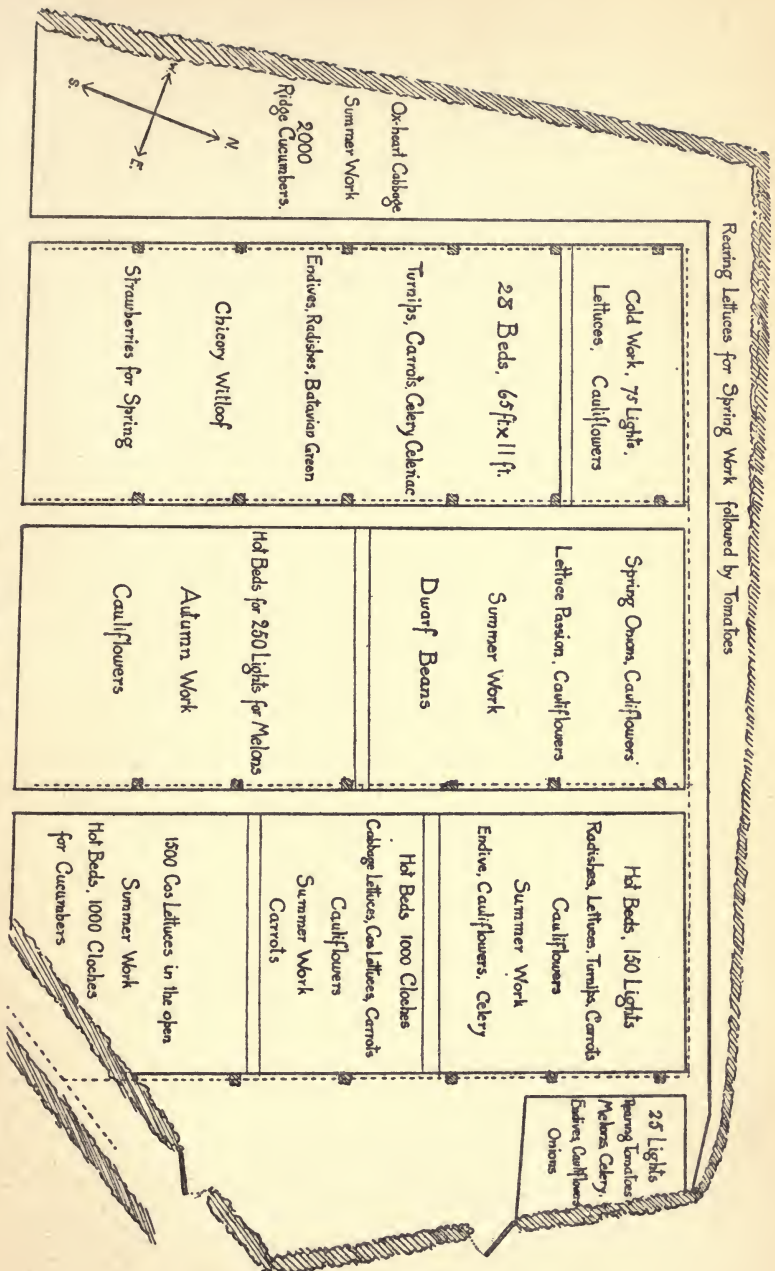

Rearing Lattices for Spring Work followed by Tomatoes

Cold Work, 75 Lights,
Lettuces, Cauliflowers

25 Beds, 65 ft x 11 ft.

Turnips, Carrots, Celery, Celeriac

Endives, Radishes, Batavia Green

Chicory Willowof

Strawberries for Spring

Spring Onions, Cauliflowers

Lettuce Passion, Cauliflowers

Summer Work

Dwarf Beans

Hot Beds for 250 Lights for Melons

Autumn Work

Cauliflowers

Hot Beds, 150 Lights

Radishes, Lettuces, Tompks, Carrots

Cauliflowers

Summer Work

Endive, Cauliflowers, Celery

Hot Beds 1000 Cloches

Cabbage, Lettuces, Cauliflowers, Carrots

Cauliflowers

Summer Work

Carrots

1500 Cos Lattices in the open

Summer Work

Hot Beds, 1000 Cloches

for Cucumbers

25 Lights

Rearing Tomatoes
Melons, Celery,
Endive, Cauliflowers,
Onions

Fig. 1. Plan of Tiptree French Garden.

possible to the position of the hotbeds, in order to save excessive carting. In the vicinity of the stacks and roadway (the latter should be 10ft. to 12ft. wide) it must be very solid and well made on account of the carting traffic to which it will be subject. If possible, there should be an ingress and egress in order to avoid turning the cart, and thus cutting up the ground and perhaps treading on the beds next to the stack.

The collection of the material and implements, the different operations for the preparation of the ground, the supply of manure, the instalment of the irrigation, and the breaking up of the soil necessary for filling up the frames the first season will occupy three months, even when everything is on the premises. Though we can well understand the natural anxiety of the owner to see crops of some description on his ground, we would, however, strongly advise him on no account unduly to hurry, as crops grown in unprepared ground rarely give satisfactory results as a market produce.

Manure.

Manure is the backbone, as it were, of the intensive culture of vegetables. It is employed for three purposes:—First, for the heat obtained by its fermentation; secondly, as nutrition for the plants when fermentation has ceased; and thirdly, as soil, when it is decayed and reduced into a powdery condition.

The only manure used in a French garden is that from horses; it must be strawy and long. The best manure is collected from stables where at least six or seven horses are kept. Around Paris the gardeners

collect manure all the year round. When it is not wanted it is stacked in heaps 12ft. to 14ft. wide and 40ft. to 50ft. long, according to the space available for the purpose. They are careful to leave two or three apertures in the centre of the heap for the escape of the vapour, or the manure would soon "fire" under the action of the fermentation. This manure, when in heaps, gets absolutely dry, and when the time comes for the making of the hotbeds it is combined with fresh manure in proportions varying with the heat required to be generated. By capillary attraction the dry manure soon absorbs the excess of moisture from the fresh manure and ferments again, giving a mild and more constant heat. The dry manure is absolutely necessary, especially for the cultivation of vegetables which require a mild heat.

In some quarters where the supply of manure is limited the shortage is made up with leaves. The heat obtained with these is very mild, but very lasting. When leaves are used for the making of the hotbeds care must be taken to select only those from hard-wood trees—oaks, elms, beeches, ashes, &c. One of the drawbacks to the use of the leaves is that the decayed product at the end of the season cannot be utilised as soil, as it is too swampy; it is only available to manure the ground in the open.

One great drawback to the extension of intensive culture in England is the scarcity, or rather one should say the difficulty, in obtaining manure. This is due in a great measure to the ever increasing use of motor and electrical power. Whereas a few years ago manure could have been obtained in large quantities from almost any town, the sources have become circumscribed, and unless one is happily situated the cost of

carriage may be very heavy. We must bow to the march of the times and say "Kismet." However, Englishmen flatter themselves upon being sportsmen, and where you find an Englishman you generally find either a "humble Dobbin" or an aristocratic "Persimmon"—a love for dumb animals in general.

Although motor and other power have become as general in France as in England, if not more so, manure can always be obtained. The reason is that that which is a waste in England in certain places is an asset in France, and all owners of horses in France know it. In England we have to abide by the regulations of the municipal bodies, and "middens" in large towns have to be cleared three or four times a week at the low price obtained. But, as we have already said, the areas are few and far between, and the cost of railway carriage is the great stumbling-block. This difficulty is worthy of the consideration of the railway companies, as a large amount of money could be made out of a very valuable article by agriculturists throughout our islands. Owners of horses could bed their steeds with litter suitable for the land, and this would encourage British farmers to cultivate wheat, oats, or barley, and they would also derive a profit, and a considerable one, from the sale of the manure.

When starting this system of gardening the beginner will probably be astounded at the very large amount of manure required year after year, and may wonder how intensive culture can pay its way with all the attendant outlay in material, labour, &c. He may also be dubious about the wholesomeness of vegetables grown entirely in manure.

That the manure bill seems enormous must be admitted, but on consideration it will be seen that instead of being a loss it is a valuable asset. Manure, as already explained, is used on account of the heat produced through its fermentation, and it is this heat which repays the grower by enabling him to produce his crops out of season. When fermentation has ceased, the plants receive during the advanced spring their vitality from the sun and seek their nourishment by plunging their roots into the manure which has now become more or less decayed. The vast amount of humus which is stored over the site of the old hotbeds enables the grower to set his plants closer together than in the ordinary method of gardening, so that he can procure three times the quantity of produce in the same space. At the end of the season the old hotbeds are thoroughly decayed. The manure is then broken up and made into a fine and workable condition, either to be used as "black soil" for the following season or as a top-dressing for the open ground. In the course of a few years the "soil," which represents one half of the bulk of the original manure used, has formed a new and practically artificial piece of ground, the nutritive power of which produces abnormal growth.

Any surplus is generally sold to farmers for use as a top-dressing, or to gardeners to mix with compost for pot-plants. The fermentation to which manure is subject eliminates any impurities found in it whilst fresh. It will also be found by experience that it is quite immune from any insect and other pests, but worms are always numerous; it is also free from weeds, except those from wind-blown seeds, which are always unwelcome visitors.

Hotbeds.

Upon the preparation of the hotbeds depends the success of the early crops. One cannot lay down a hard and fast rule as to their making, as the gardener will of necessity have to adapt his working in accordance with his surroundings. Assisting Nature is the constantly recurring keynote in intensive culture, and we must always come back to it.

Plants require heat, but it is a well known fact that too much is as harmful as too little. Therefore the heat must be regulated by the quantity and quality of manure used and in accordance with the crops under cultivation, and the temperature must be kept as even as possible, so as to provide natural conditions for growth. Fresh long manure gives too much heat; short gives too little through being slow in its reaction, especially in the very early spring, when, if the weather is too wet, it becomes saturated and will not ferment at all. Some growers start their hotbeds later in the season than others owing to the heavy cost of their manure. Moreover, a less quantity is needed later in the season than earlier.

The crops it is proposed to deal with here do not require a temperature of more than 50degs. to 55degs. F., with the exception of the seedlings of Melons and Endives. The average temperature in January and February is 40degs. to 45degs., and as the glass and mats make up an equivalent of 6degs. F., only an extra 5degs. or 6degs. are required to make up the necessary amount of heat. This temperature must be maintained for eight to ten weeks, according to the time of laying down the beds. The depth of manure required is 10in. when trodden, and 12in. to 13in. when loose.

Heat is obtained over this long period by employing in combination dry, or three or four months' old, manure, and fresh manure. This gives off heat immediately, while the old takes time to do so. No advantage is gained in either earliness or quality of produce by making hotbeds thicker than stated, for if the heat exceeds 55degs. to 60degs. in the early spring, when there is not a great amount of light, it encourages a leggy and soft growth, and decay follows as a natural consequence. For a 65ft. by 5ft. 4in. bed (five frames) and a 10in. pathway, seven to eight tons of long manure suffice. This includes the filling or lining in the paths during February and March. As the making of the hotbeds proceeds, a lesser quantity is required, and late in February five-and-a-half to six tons are enough, for as time goes on the temperature rises and with it the vitality of the plants.

When laying down a hotbed, the necessary quantity of dry manure and about half its bulk of fresh are placed in separate ridges. The position of the bed is marked out with canes, or by the most convenient means, every 10ft. or 12ft. Boards are placed on one side as a guiding-line, and at the same time serve to carry or wheel manure upon, &c. A space of 3ft. or 4ft. is generally allowed as a trench for the workman to manipulate the manure. The outsides of the beds are the most difficult to do correctly. They are built vertically, with the straw always turning inwards. In building the bed, outsides are always a few inches more forward than insides, the trench then forming a semicircle.

The two sorts of manure having been well shaken together, great care must be taken to keep the bed

absolutely level, in order to obtain an equal fermentation and even heat throughout. When reaching the end of the bed, the trench is turned round, so as to build the outside edge before closing, the bed being always closed on the side. The bed having been laid, it is trodden down, beginning from the outside and finishing in the centre. It is generally trodden crossways as well as longways. When this has been done, any unevenness is rectified with more manure. Beds made between January and March will not require watering, generally speaking, as the manure is sufficiently wet without such an addition.

The frames are next placed in position with a wisp of strawy manure under each corner to keep them firm; they are then carefully straightened and levelled. A good barrow-load of manure is spread in each frame and so arranged that the soil when covered will be even in thickness and the crop at an even distance from the glass. When levelling the soil thus placed, care must be taken to press it with the back of the rake against the boards, so that when it shrinks no gap will be left to harm the tender roots therein.

In making up a cloche bed the soil is placed in a ridge in the centre, and is only levelled when the adjoining bed is made up, so as to be able to rake the edges firm and level. If Carrot or Radish seed is sown in the frames it should be after the soil is level, thus avoiding unnecessary trampling later on.

It is absolutely essential that a bed be finished the day that it is started, especially in January and February, as bad weather may ensue. No hotbed must on any account be laid down in snowy or frosty weather. The reason is well known. Anything, almost, changing its nature, requires heat or energy

from the nearest source. The energy of the fermentation taking place in the manure is work in vain when it tries to get that same energy out of snow and ice. The cold remains in it, and try as it will it cannot produce heat itself, and so fermentation is retarded.

When a hotbed is becoming exhausted and the heat diminishing, it is necessary to "line" the frames with fresh manure. In the pathway between two rows of frames long, dry, straw manure is used for this purpose. It is carefully tipped from the "hotte" on the edge of the frame and placed in the pathway with the hands. For the outside edges "short" manure is preferable, and it is advisable for it to be well shaken and broken before it is brought into position. It is made level with the top of the lights. The edge is first built, and then the workman treads it down and presses it close on the side at the same time with the back of his shovel.

In the cloche beds short manure is supplied whenever needed to keep the pathways level with the soil. It is carried in a hand-basket, thereby avoiding the danger of breaking the cloches.

Irrigation.

Water is the second important agent in the intensive cultivation of vegetables: in fact, it is an impossibility to follow the principles of the system where it is not readily available. To obtain a constant growth and to help Nature it is necessary to make up the deficiency of the moisture in the ground, so that the roots of the plants can absorb the requisite nourishment. The artificial soil in which the plants are grown is very porous, and the vegetables themselves are of a very sappy nature. Moreover, the

available space for their development is very limited owing to the system of intercropping adopted, while the number of roots is naturally very great, and they are in full activity. Water is the only element which can maintain the plants in a constant state of growth, and is therefore absolutely indispensable.

Rainwater, though preferable, is quite inadequate for the purpose. True, it could be collected in an artificial pond and pumped up into a tank; but this entails a very great outlay, as well as considerable demands upon valuable space. Most of the growers who practise French gardening have to obtain their supply from a water company, or from a well. In the latter case it must be collected in a tank, duly exposed to the air, and afterwards mixed with the company's water. When water has to be obtained from a company, the size of pipes is based first on the size of the company's main, and secondly on the pressure per square inch. The higher the pressure the smaller the diameter of the pipes need be, as the flow would be too strong and harmful to the crops. In any case enquiries ought to be made as to whether the company is able or willing to supply the necessary amount all the year round.

When entering into a contract with the company, allowance ought to be made for the great quantity necessary from May till the end of August; and an agreement should be made for twelve months, so as to equalise the amount required during the summer with the smaller quantity needed from September and through the winter. The outlay for irrigation when the water is obtained from a company is about half that charged for one's own supply; but whenever possible it is preferable to have a private supply, and

this in six or eight years' time will prove a sound investment.

In a small garden it is easy enough to obtain the necessary quantity of water and to find time to water the plants. In a garden run for profit and where intensive cultivation is carried on on an extensive scale it is absolutely necessary to make special arrangements, first to water the plants when it is needed and at the proper time, and secondly to water all the garden within a limited time. This will be easily understood when in June, for instance, the Carrots and Cauliflowers are in full growth in the old hotbeds, in the cold work, or in the open ground. When the Cos Lettuces, Endives, Turnips, and Radishes are occupying the spare ground, the Melons are also growing fast in the lights. The whole garden is in full activity, and it is therefore important to water abundantly and quickly.

Up to 1870 in the gardens around Paris watering was chiefly done with the cans; after this date the hose was introduced therein. At first the pipes were of 1 in. diameter, and the water was stored in a tank and pumped by a horse. This was soon found inadequate owing to the small amount of water distributed in the garden. The system of pumping was also discontinued on account of the jerk felt by the horse when the sucker was ascending. The size of the pipes was increased and a pump with three suckers was adopted. A larger quantity of water was obtained and the strain was evenly equalised owing to the position of the different suckers.

About 1880 the first steam motors were employed to replace the horse. The standing pipes were done away with, and in their place hydrants were fixed

direct on the pipes and sunk into the ground. Now the steam motor has been changed for the gas or oil engine, and in some up-to-date places electricity does the work. With the full-sized pipes, a two horse-power motor, and a tank holding 5000galls. of water fixed on a pier 15ft. high, a man can water thoroughly two acres of ground in a day.

To obtain a supply for three men watering the plants in the frames, or two men using the hose, the flow-pipe from the tank must be 4in. in diameter; while the main branch running from east to west, or *vice versâ*, is 3in. in diameter. The branch pipes, set perpendicularly to the main and 70ft. apart, are 2in. in diameter. The hydrants are fixed at a distance varying between 24ft. and 28ft., according to the length of the pipes. One hose $1\frac{1}{2}$ in. in diameter inside and 30ft. long is sufficient to water every inch of the garden.

CHAPTER V.

Tools and other Appliances.

As in the case with most of the appliances employed in the equipment of a French garden, the *marâchers* have tools of their own pattern, which are very light and handy and thus conducive to quick and easy working.

Spades.

These are of steel, and 1ft. in depth. They are made perfectly flat in order to prevent the clogging of the soil when digging; their length (inclusive of the handle) from end to end is 5ft. 3in.

Shovels.

Two sorts of shovels are used: one is round and slightly pointed at the end, and the other is angular. The handle has a sharp bend near the socket, and is 3ft. 6in. long. In use, the workman lays the shovel flat on the ground, and pushes it with his knee. The long handle is indispensable when throwing the soil or decayed manure to a distance or a height (Fig. 2).

Hoes.

Hoes are rectangular in shape, 4in. to 5in. deep and 6in. to 9in. wide, according to the size required. The socket is the shape of a swan-neck, and holds the short handle of 2ft. 3in. The workman is obliged to keep

the hoe flat on the ground; this enables him to cut the weeds without pegging the ground, as is the case with hoes of other form. In French gardening, hoes

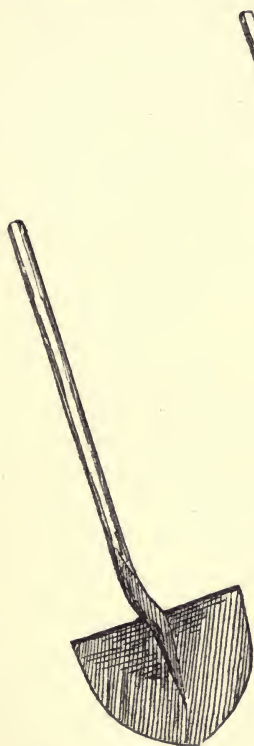

Fig. 2. Shovel.

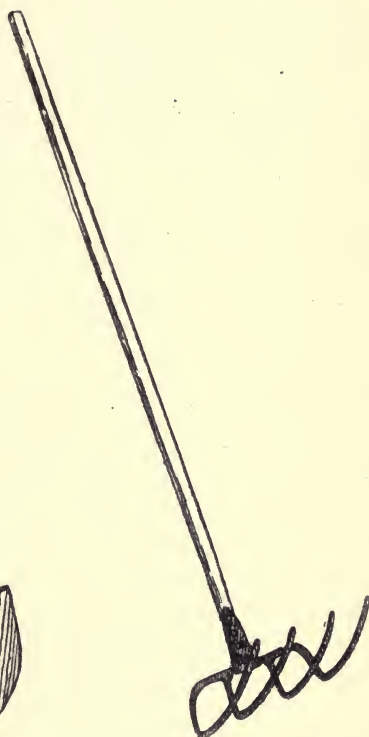

Fig. 3. Bent Fork.

are also used for earthing-up potatoes or kidney beans in light ground.

Rakes.

The length of the rakes varies between 12in. and 20in. The size generally adopted is 18in., with

by sliding his hand round the handle without having to rest it on the ground. By this method also he can, when watering in the open ground, empty two cans at a time.

Baskets.

Baskets, or "hottes," are made of wickerwork, and are for the purpose of carrying manure or soil from one

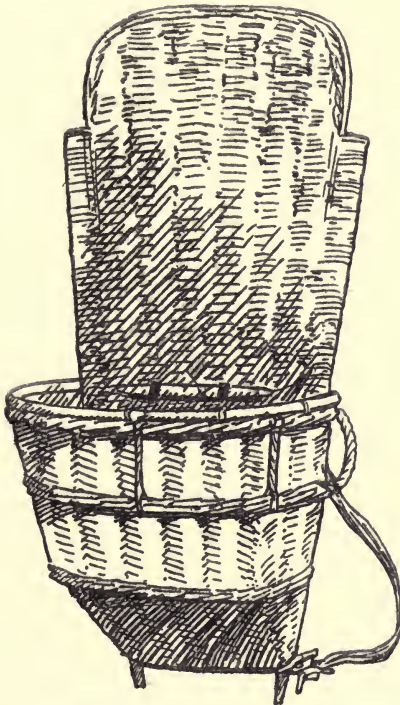

Fig. 4. Basket or Hotte.

part of the garden to the other. They are carried on the workman's back by means of two leather straps round

the shoulders. As a rule, the French garden is very compact, and even the main paths are scarcely over 4ft. wide, whilst the paths between the frames or the beds never exceed 1ft. Obviously, therefore, it would be quite out of the question to use a barrow in such circumstances. Baskets also obviate the heavy treading of the ground and dispense with the cutting of paths. For loading the basket (Fig. 4) the workman

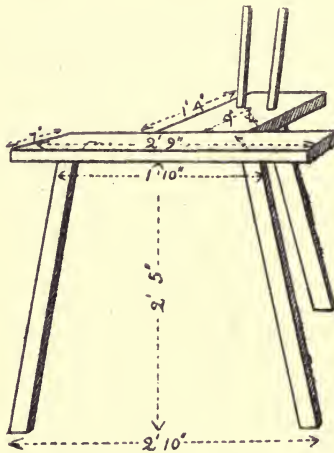

Fig. 5. Basket-loading Stand or Chargeur.

fixes it on a special stand made of wood or iron, called a "chargeur" (Fig. 5).

Hand-Barrow.

As shown by Fig. 6, the hand-barrow is without legs, to enable the workmen to pass with it between the frames, and rest it wherever it is necessary. It is used for carrying both the lights and the produce.

Cloche-Carrier.

In this we have a very simple and useful appliance made to carry a dozen cloches at a time. The workman stands in the centre, and has six cloches in front

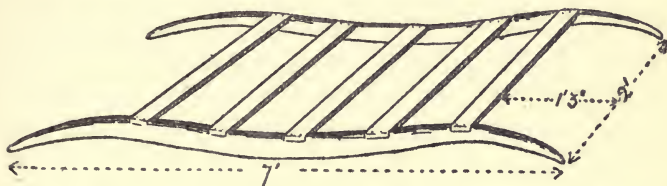

Fig. 6. Hand-Barrow for carrying both Lights and Produce.

and six at the back of him. Besides being a labour- and time-saving appliance, the use of a cloche-carrier (Fig. 7) tends to a certain extent to prevent the

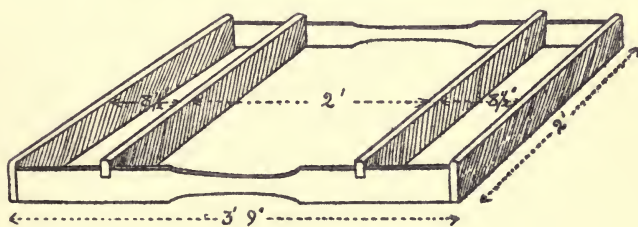

Fig. 7. Cloche-Carrier.

breakages so common when carrying the cloches by hand.

Copper Reel.

This is to fix at the corner of the bed when watering with the hose. It prevents spoiling the plants at the corner, and also obviates a sharp quirk in the hose, which by stopping the water suddenly might cause it to burst.

Blocks.

Plants growing under lights require a certain amount of ventilation, which varies according to the stage of growth they are in, their nature, and the time of the year. For this purpose blocks of wood, 7in. by 3in. by 1in., are employed. When the plants are very young, or early in the year, the blocks are set flat between the frame and the light. Later on, when the plants have grown stronger, the blocks are laid edgeways, while when everything is favourable to their growth and when the plants are well established, the blocks stand upright. Sometimes, too, one light is opened from the top and the next from the bottom, to ventilate the plants at the bottom of the frames as well as those growing at the top. The easiest way to open the lights is from the top, as they are held in their position by the clips fixed at the bottom of the frame. But this must not be the rule, especially in the spring; when the plants are very tender the lights must be opened on the side opposite to the wind. It is therefore advantageous to have a set of blocks to spare, so as to be able to place them at the bottom of the last row of frames. When it is necessary to open the lights from the bottom, the second row of blocks is used for the first row of lights, the third for the second, and so on, thus saving the carrying of the blocks from the first row to the last.

Pegs.

To give air to the cloches, pegs of oak with two notches are used for the purpose, as shown in Fig. 8. The peg is 11in. long, and pointed at the base, $1\frac{1}{4}$ in. wide, and $\frac{1}{2}$ in. thick. The notches are 2in. apart from

the top; this leaves 7in. for the point, which is fixed in the ground. Care must be taken when making the notches to cut their base at a right angle with the

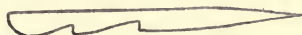

Fig. 8. Cloche Peg.

back of the peg; this is to facilitate the dropping of the cloche when the peg is pushed on the outward side.

Buildings.

The provision of a shed is of first importance for packing, washing, and bunching vegetables, and also for housing lights and mats when out of use. The ordinary size for a garden of two acres is 75ft. long, 20ft. wide, 9ft. to the eaves, and 14ft. to the top of the roof. One part, generally about 20ft., is entirely closed. The floor is concreted. There should be two tanks for washing Carrots, Turnips, Radishes, &c., and a drain for carrying away dirty water after the washing is complete. A cellar is also necessary for the storing of the Melons in hot weather, when they cannot be sent to market. A second part should form an open shed for storing implements, lights, and mats. A carpenter's bench is also an extremely useful adjunct, as the numerous repairs to the appliances may then be undertaken during the wet weather. A loft over the closed-in part of the shed will be useful for storing cloches after being repaired, and for keeping seeds, &c. A stable and cart-shed should adjoin the other shed. All these buildings should be on the north side, facing the south. Facing the shed should be left an open space for stacking the manure. Any

room that is to spare may be usefully employed for raising Melons, Cucumbers, Celery, &c., for planting in other portions of the garden.

Frames.

The basis of a French garden is the frame. It is made to hold three lights, and is built as shown in

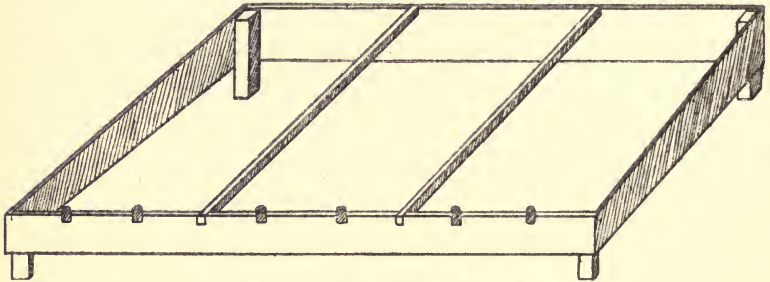

Fig. 9. Frame for three Lights.

the illustration (Fig. 9). The top board is 9in. wide by 13ft. long by 1in. or $1\frac{1}{4}$ in. thick. The bottom

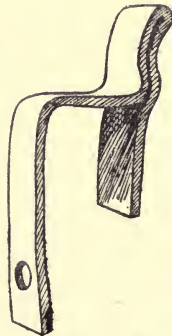

Fig. 10. Clip for Front Edges of Frames.

board is 7in. wide by 13ft. long by 1in. or $1\frac{1}{4}$ in. thick. The two sides joining the two boards are 4ft. 3in.

long. The four boards are nailed and joined together at each corner on a block of oak, 3in. each way, and 10in. long for the top and 8in. for the bottom; these four blocks project $1\frac{1}{2}$ in. at the bottom of the frame. Inside the frame are two iron tee-bars, $1\frac{1}{4}$ in. wide, hooked down at each end to clip the board. To prevent the lights from slipping off when lifted by the handle at the top end, two clips (Fig. 10) for each light are fixed on the frame at the bottom board (Fig. 11). The frames are never tarred or painted. If this were

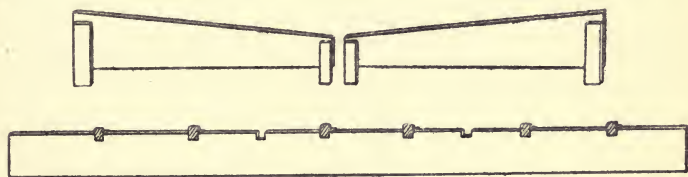

Fig. 11. Front and Sides of Frame, showing Clips in Place.

done the oil would evaporate under the action of the sun, and the vapours confined between the lights and the frame would be injurious to the plants.

Lights.

The dimensions of the lights (Fig. 12) are 4ft. 5in. long and 4ft. 4in. wide. The styles and the top bars are 2in. each way, the bottom bar being $2\frac{1}{2}$ in. by $1\frac{1}{2}$ in. It is made of either oak, pitch-pine, or deal, though the last is not to be recommended, as in dry weather it is liable to split. The three sash-bars are small iron tee-bars, $\frac{1}{4}$ in. wide. The handles, which are fixed on the top and bottom bars with two clips, lie flat on the light. There is practically no projection outside the frame when the three lights are fixed on it. This is an important point when we know that the allowance

for each path between the frames never exceeds 10in. The glass used for the lights is 21oz. horticultural third quality, 15in. by 12in. Each row takes $3\frac{1}{2}$ panes. 16oz. glass is often used, but it must be of good quality: the cost is about the same as for the 21oz. already mentioned. To keep a

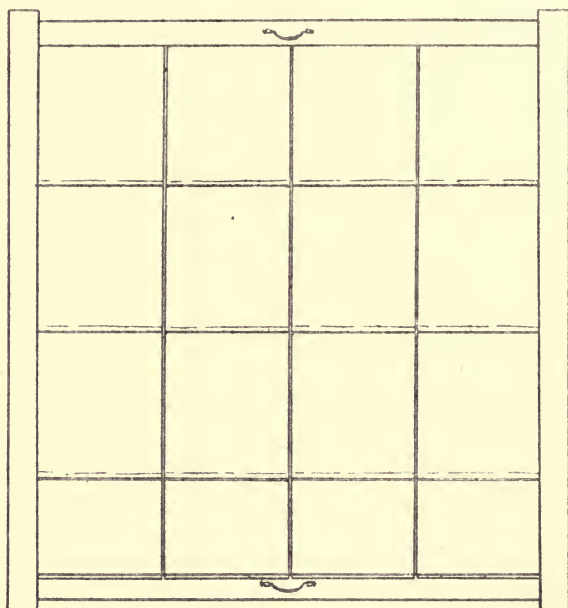

Fig. 12. Light for Frame.

light in good working order it must be painted on the outside once a year and on the inside every two years. Fig. 13 illustrates the method of mortising the corners of the light shown at Fig. 12.

Cloches or Bell-Glasses.

Bell-glasses have been employed in France since the beginning of the seventeenth century, when Oliver

de Serres saw them in Montpellier. At that period they were 1ft. in diameter and 1ft. high. They were made in Italy, where the glass industry was in a much more advanced state than in France. La Quintime used them in the Potager de Versailles; they had not changed in size or in make at that period. When in 1820 the Parisian growers began forcing Cos Lettuce, they were then made wider and higher, though very uneven in size, owing to the difficulty

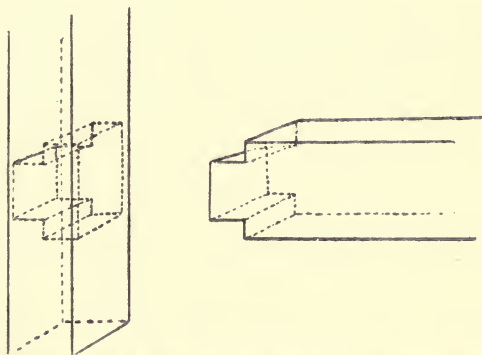

Fig. 13. Method of Mortising corners of Light shown in Fig. 12.

experienced in the blowing operations. After many experiments the makers were able to offer cloches, or bell-glasses, made of a light bluish tint and of better shape. The standard size is now 17in. in diameter and 15in. in height, the weight being about $5\frac{1}{4}$ lb. These cloches are made in Lorraine, near Nancy, where the sand is suitable for their manufacture, imparting to the glass that necessary bluish tint which prevents the burning of the plants when the sunlight is strong. They are known in the trade under the name of Cloches Maraîcheres. The best time to buy cloches is from the end of June till the end of August,

so as to have them ready for use by 1st October. They are bought in crates holding from 200 to 300; this method of packing greatly diminishes the chances of breakages, as the crates have to be lifted by machinery.

There are two classes of French cloches—first and second quality. The first quality is as regular and even as it is possible to procure them; the second class consists of those with some slight fault—either too big or too small, too thin, or irregular in shape. The latter are from 6s. to 8s. cheaper per 100 than the former. Cloches are indispensable in French gardens, and form a “complement” to the frames and lights. They are chiefly used for growing and rearing Lettuces from August till May. Formerly the gardeners used to mend broken cloches by spreading white lead on the pieces and then joining them together. They covered the crack with another coat of white lead, and finally with a strip of narrow linen tape. They were then put away in a sheltered place to dry. This custom, however, has been discontinued, owing to the high wages paid to workmen and the little time to spare.

Cloches when not in use are stacked on a firm and level ground which has been previously covered with straw or hay. They are piled up in heaps of five or six, with a square block of wood (2in. by 2in. by 1in.) separating one from the other to prevent jamming or smashing. Old mats are then spread over them to prevent breakages through hailstorms.

Mats.

These constitute an important shelter in the winter, but more particularly in the spring, when the young

and tender plants are growing in the frames or under the cloches. French mats are made entirely of rye-straw, laced with four or five seams of tarred string. They are dipped in a solution of sulphate of copper ($7\frac{1}{2}$ lb. to 25galls. of water) for the dual purpose of keeping away the vermin and to preserve them. They are from 5ft. 6in. to 6ft. long and 4ft. 6in. wide, and weigh from 10lb. to 11lb. It is very important that they be kept in good order. They should never be allowed to remain wet, but spread out to dry whenever possible, by being stood up edgewise. An experienced grower uses them with great care and judgment. When the plants on the hotbeds are growing too fast, or are getting drawn, which is generally caused by the heat of the manure or by mild, damp weather, he will not spread the mats on the lights at night; he prefers to see the glass white with frost in the morning. But, should the reverse conditions obtain, he will spread the mats early in the afternoon, "shutting the sun in," as the French saying goes. When the weather is too cold, he leaves them on nearly all day if necessary, letting the daylight in for one or two hours.

Mats are also used for shading purposes: in April and May for Cos Lettuces, and in June for Melons and Cucumbers. French gardeners prefer shading with mats, as they can always take them away from the glass in dull weather—an obvious advantage over shading with limewash and similar preparations. Shading by means of mats incurs more labour, but the plants are always sturdier and healthier than when any other method is adopted.

CHAPTER VI.

Calendar of Operations.

AUGUST.

THE uniformity of work in a French garden is so important that everything must be done automatically; a delay in the work caused by either accident or negligence will very often spoil a crop or the rotation of crops for the whole year. It must be borne in mind that the material is costly, and that current expenses are very heavy, and it is therefore necessary to obtain from the frames, the lights, and cloches the best results, and have them at liberty in time to be utilised for another crop. The only plants grown under the lights and cloches during the summer are Melons and Cucumbers. The crops grown previously under them must either be cleared off the ground or be strong enough to grow in the open. A grower must also consider in making out his programme for the season:—

First, his market—a very important point in England, where many vegetables grown under the French system are little known, or not known at all. Certain varieties of vegetables find a better market in some localities and over a longer period. Secondly, what he is more apt at growing; and thirdly, what suits his ground best. Though Turnips and Carrots are extensively grown in a French garden, these crops could hardly be successfully cultivated in heavy ground,

especially in the first few years; whilst Tomatoes, Melons, Cucumbers, Cauliflowers, and Salads will flourish in soil of a heavy nature. With the early Cabbages and Winter Onions the Turnips and Carrots will constitute the main crops in a French garden in the spring in light ground; but the Cauliflowers and Cucumbers can only be grown with great difficulty and where water and manure are plentiful. The horticultural year commences in August, and by the middle of that month the plan of work for the following twelve months must be arranged and well decided.

Onions.

The only varieties grown in a French garden are the Early Parisian or the Early Vaugirard. They are sown from the 15th to the 20th of the month. The seeds ought not to be more than twelve months old. Previous to the sowing, the ground should be well dug and manured, trodden down, and levelled with the rake. A layer of well-decayed manure should be spread all over the bed, and a good watering given if necessary. The seeds should be inserted broadcast and very thickly, covering them with another layer of decayed manure. The ground should be kept damp during germination by frequent waterings, which must be suspended when the young plants are coming through, to prevent any tendency to "damping off."

Saladings—Endive.

The main batch of Endive, either La Ruffec or the Batavian, should be planted in the middle of August in well prepared ground. This batch was sown early in July in a nursery-bed. The plants should be set

10in. to 12in. apart each way in heavy ground and closer in poor soil; they should be well watered in and the ground kept damp by frequent waterings, so as to get the plants well established by the end of the month. The batch of Endive La Rouennaise planted early in July on the old manure-beds will be ready by the middle of August. When the leaves are very dry they should be brought together towards the centre and tied up with rye-straw or raffia, in order to bleach them. They will be marketable in five or six days after the tying. When tied they must be closely watched and pulled out when ready, or they would soon decay. They are generally tied in three or four batches, to obtain a succession.

Lettuces.

The batch of Cabbage Lettuce Vauxhall Defiance or All The Year Round, and of Cos Lettuce Paris Grey, sown early in July, should be planted out 10in. apart in a bed 4ft. 6in. wide early in the month. The ground should be kept damp, to facilitate a quick growth and to avoid any possibility of a check. A small batch of Cabbage Lettuce Little Black Gott and Cos Lettuce Paris Grey should be sown at the end of the month under a few cloches. The number of seeds for every cloche must not exceed 250, as at that time of the year the young plants would soon damp off if they were sown any thicker. The ground is generally well watered previous to the sowing and kept damp by covering the cloches with mats. The Cos Lettuces planted in the old beds early in July will require ample watering, which must be done in the early morning or late at night, as if done during the day the leaves are liable to be scorched by the sun. The Cabbage

Lettuces—planted as an intercrop in July among the Celery—Cos Lettuces, or Endive will be ready early this month. They must be cut as soon as possible, or they will run to seed. When the ground is cleared, a good hoeing and watering should be given.

Corn Salad or Lamb's Lettuce.

Seed of this salading, so much appreciated during winter, should be sown broadcast in beds either 4ft. 6in. or 10ft. wide, one batch early in the month and two others at an interval of a fortnight. This plant does not require freshly dug ground: a good hoeing and levelling with the rake are preferable. The seeds should be sown thickly, as the germination, especially in dry weather, is very difficult. The ground must never be dry till the plants are well up. Afterwards no special care is called for other than the watering should the weather be too dry in September.

Celery.

The Celery planted as a main crop will be well established this month and must receive frequent waterings. Owing to its strong and numerous roots the beds must not be allowed to go dry; constant watering is therefore necessary to prevent this happening and checking the growth. In private establishments, when Celery has been sown very early, a few plants will be ready in August; these may be blanched by spreading mats on the top of the plants.

Carrots.

The batch sown in July will be growing fast; the plants will require thinning and weeding before they occupy all the room. Ample watering will be found

beneficial at this period, especially when the place is intended for the pricking-off of the Cabbages early in October. A sowing of the Early Parisian Carrot can be made in August in a well sheltered position for winter use.

Cauliflowers.

Cauliflowers planted as an intercrop among the Melons can now receive all the water they require. Caterpillars of the White Butterflies will be troublesome to this crop; they must be picked off by hand early in the morning and destroyed.

Melons.

The first batch of Melons planted early in April will be practically over. The ground must be cleared of the old vines and leaves and receive a good hoeing for the Cauliflowers planted there early in July. The second and third batch will be in full bearing; the plants must on no account be allowed to get dry at the roots, or the fruit will remain small. The fourth batch, planted late in May or early in June under the cloches, will have fruit set early in the month. The first fruits appearing must be kept, and the growth must not slacken or the fruits will not have time to ripen. When possible, the cloches will be removed from the last batch of Melons, to be replaced with frames and lights, to increase the room for the good growth of the side-shoots and to hasten the cultivation of the crop. The frames and lights will be obtained from the Melons planted early in April.

Cucumbers.

This crop requires heavy watering nearly every day. The fruit must be picked every two or three

days. The lights should be set on four bricks to give them ample ventilation. It would be unwise to take away the lights altogether, as the young fruits cannot swell in the open, and the crops would consequently suffer.

Cabbages.

One of the most important crops in a French garden in the spring is the Cabbage Ox-heart, dwarf strain, which should be sown at the end of the month. The seeds must be obtained from a reliable source, and better results will be obtained if these are two or three years old, as plants from young seeds readily bolt. They should be sown in a nicely prepared bed, well dug and levelled; the ground should be covered with a layer of well sifted manure. They are generally sown in a frame, to be covered with lights should the weather prove unfavourable to their growth. Germination must be stimulated by light waterings once or twice a day if necessary.

Spinach.

Winter crops of this vegetable are sown from the 15th to the 20th of the month in the open in well prepared ground. It should be sown broadcast in beds 4ft. 6in. wide when it is intended to cover it with frames and lights during the severe weather to obtain a constant supply, or in beds 10ft. wide for picking early in the spring. Some growers sow the seeds in drills between the last batch of Endives which were planted as inter-crop between the early potatoes. The best variety is Monstrous of Viroflay. The seeds will require light waterings till the end of September. Picking can start in October.

Beans.

French Beans sown late in July will require a good hoeing a week after the germination of the seeds. Late in the month the plants should be earthed up and spread out from the centre with a little soil. This operation is to check the growth of the foliage and to ensure the breaking of fresh roots on the part of the stem covered.

Chicory.

Chicory Witloof sown in May will develop a mass of leaves in August. The biggest of these should be removed once every fortnight. A sprinkling of nitrate of soda—2oz. per square yard—will greatly stimulate the growth of the roots.

Strawberries.

Runners potted in “forty-eights” in July will require frequent spraying to get them well established. When the plants are growing, spraying with a mixture of flowers of sulphur and water (1oz. sulphur to one gallon of water) will be found an excellent preventive against attacks of mildew and red spider. When the space is available the runners of Strawberries for the following year’s stock can be planted at the end of the month in a bed 4ft. 6in. wide, richly manured and well dug. The plants should be set 1ft. apart in two rows and 1ft. 3in. from each side of the bed. They must be well watered in and receive the necessary attention. The variety grown for forcing in frames is Docteur Morere, named after a medical practitioner of Palaiseau, a district where a great area of ground is devoted to Strawberry culture. This variety is irregular in shape but a good grower,

producing first quality fruit, and an excellent traveller. The Royal Sovereign is also a very good sort for forcing.

Cardoons.

The ground must be hoed well and topdressed with rich manure. The plants will require abundant waterings this month, and for this purpose it is advisable to make a shallow trench round the stump of the plants, to hold the water.

General Work.

Apart from the few sowings and planting, the chief work this month will consist of watering, which must not on any account be overlooked, especially among Cauliflowers, Carrots, and Celery. Melons will need to be looked over very frequently for the picking of the fruits; during the hot weather they must be examined at least twice a day. Cucumbers will be in full bearing, and care must be taken not to overlook a fruit ready to cut, or it will soon absorb the sap, to the disadvantage of the young fruits. The lights under cover in the shed can receive a coat of paint, which will dry before the wet weather sets in. In a garden the painting and glazing of lights must be well advanced so that such structures may be available when they are required.

SEPTEMBER.**Onions.**

Onions sown in August will be ready to be pricked off from the 20th to the 25th of this month. When they are well up they should be kept somewhat dry in the seedling bed, to get them clean and hardy when planting them. Pricking-off should be done in beds

10ft. wide in a well sheltered part of the garden. The ground must have been previously well prepared by heavy manuring and careful digging. The plants should be carefully lifted from the seedling bed, the tips of the leaves trimmed, and the roots cut $\frac{1}{2}$ in. from the collar. They should be pricked off 3in. or 4in. apart, care being taken to press the soil firmly against the roots to prevent worms from "lifting" them. They should be well watered-in and receive the necessary moisture if the weather is fine and warm.

Endive.

Plants set at the end of August should now be well established; the ground must be kept clean and well open, and the plants must not suffer through dryness at the roots, or, later on, the centre of the leaves will decay. The plants set late in July will be ready this month. If a heavy watering is given before the tying of the leaves no other care will be needed before dispatching to market.

Lettuce.

Plants sown at the end of August will be ready to be pricked off early this month—thirty under a cloche. The ground should be well prepared and covered with a layer of fine decayed manure. When this has been spread over the bed the soil should be pressed down with a flat piece of wood, to obtain a levelled surface on which to set the bell-glasses. They should be set three rows per bed, with an inch between each cloche. If the sun is too hot the mats should be spread over the glass, to keep the ground sufficiently moist. When the plants are well established, ventilation in moderation can be afforded. Another plot

similarly prepared must be ready at the end of the month for the final planting—four plants per cloche. This batch of Lettuce is grown first, when there are many bell-glasses at liberty and not needed for the pricking-off of Lettuces in October; secondly, to utilise the bell-glasses which will be wanted for the second transplanting of Cos Lettuces in November, as this batch of Lettuces is marketable by the middle of that month.

Corn Salad.

A last batch can be sown early in the month if the seeds sown previously have not done well, or where a great quantity is required. The beds of the young plants as well as the seedling beds must receive all the moisture needed at that period.

Carrots.

Carrots sown in July must receive ample watering during this month, in order to assist growth and prevent the cracking of the roots, which always happens when the plants have been kept too dry, and their growth is stimulated by a watering or heavy rain.

Celery.

This crop will require heavy watering at least every two days. The early Celery Chemin may be bleached from the 10th of the month by spreading mats across the beds over the plants. The mats will have to remain at least three weeks on the plants before they are bleached sufficiently.

Melons.

The last fruits will be ripe early this month. As soon as the crop is finished, all the vines must be cleared

off the ground. The fruits ready after the 15th of the month are generally small and lacking in flavour.

Cucumbers.

After the middle of the month, unless the weather is fine, the cucumbers can be thrown away, as the nights get too cold for them to swell.

Cauliflowers.

Cauliflowers planted in July as an intercrop among the Melons will be in full bearing during this month. They will require abundant watering, and the hearts must be covered, to keep them perfectly white. When this crop has been well grown they must be cleared off the ground this month, as later on market growers send Cauliflowers grown in the field. The main batch of Cauliflowers for the following spring should be sown in the middle of this month in frames prepared in a similar way to those in which Ox-heart Cabbages were sown in August. Practical French gardeners who grow their own seeds, or get them from reliable sources, sow 1500 seeds per frame, to obtain a sturdy growth from the beginning. The bed may require light watering at that period, but this must not be over-done.

Cabbages.

Seedling beds must be kept moist in order to obtain good-sized plants for the pricking-off in October.

Spinach.

These plants will be growing fast this month; if the weather is favourable they will require frequent

but very light waterings, early in the morning if possible. One good hoeing and weeding will be greatly beneficial to the crop, especially if it is wanted in October. Another lot of seeds may be inserted during this month, as the plants from this batch are not so liable to decay in damp and mild weather.

Beans.

This crop is kept thoroughly clean by frequent hoeing. As the nights are getting colder during this month, and the dew is sometimes heavy, care must be taken to attend to this crop, but only when the leaves are thoroughly dry. As the frames from the Melons will be at liberty they should be set with the Beans, and the lights kept close at hand in case an early frost be expected.

Chicory.

Attention to this crop will be the same as in August, where this culture is a feature of the winter crop. The roots may be watered with liquid manure once or twice in the month. The growth of the leaves should be kept under control without unduly checking that of the plant.

Strawberries.

These will now be well established in their winter quarter. In France they are set pot to pot in frames and covered with lights, with ample ventilation, except in case of frost, when they are covered with mats. If runners have not been previously planted out, this must be done without delay, in order to get them well rooted before the cold weather sets in.

Cardoons.

As these vegetables are gross feeders, it is necessary to water them with liquid manure at least once a week during this month. They will reach a big size by the end of the month and, when it is needed, a few plants may be blanched by wrapping them with straw. It generally takes three weeks from the time bleaching is commenced until the plants are ready for consumption. Being a winter vegetable, Cardoons are not often blanched before November.

General Work.

Winter digging generally starts this month as the ground is cleared of the different crops, especially in heavy soil, as this allows of winter frosts and rains acting beneficially upon it. When, in a new garden, the supply of decayed manure is short, the old melon-beds should be emptied on a heap, which should be broken up twice or thrice for the pricking-off of the Lettuces in October. The ground for these Lettuces must be prepared at the end of the month. For this batch a place is generally chosen where the ground will not be needed before the following March or April. The ground should be well dug and exposed to the air and the decayed manure brought close and handy; the cloches must also be near, so as to facilitate the routine work when it commences. Glazing and painting of lights must be proceeded with, as this is the last favourable month for the work. In a new garden the cloches must be received in September at the latest, as they will be needed early the following month. During the year's operations many improvements will have been wanted either to the ground, the material, or the irrigation, and every-

thing that can be done ought to be done in September, as the crops require very little attention. The weather is on the whole favourable to any such undertakings. Manure must also be collected as fast as possible during the month on account of the good state of the roads for quick carting and the dry state of manure at that time, which greatly prevents decay and unnecessary fermentation. There is also an average reduction of one-tenth in the weight of the manure in the bulk when bought in dry weather, which is worthy of the attention of the careful grower.

OCTOBER.

Onions.

Onions must be well established in their new quarter. Whenever the weather permits it will be advantageous to hoe the ground, in order to keep it open. When this culture is undertaken on a large scale some growers keep plants in their seedling beds to prick off the following spring to form a succession to this batch.

Endive.

Endive will now be ready for consumption; the plants must be tied in batches to obtain a constant succession. This work must always be done on a fine day. In private places a few hundred plants may be lifted and set in frames fifty to sixty plants per light. They should receive ample ventilation whenever possible. This batch will be found useful in bad weather and can be kept longer, as the plants can be sheltered in frosty weather. To bleach them, spread a mat on the light, which should be left until the plants are ready for use. The Batavian Green variety generally does

well in October. Care must be taken to shelter it in frosty weather by spreading mats, hay, or leaves on the beds. It follows from Christmas onwards as it gets a very fine flavour after a few frosts and keeps better than the curled-leaved variety.

Lamb's Lettuce.

The early batch of this favourite salad sown in August will be ready this month. It makes an agreeable change, but is chiefly kept to the last, when no other salad is obtainable.

Lettuces.

Lettuces planted under the cloches in September will be doing well this month. If the weather permits they can receive ventilation, but allowance must be made if the plants do not grow as desired. All decayed leaves must be taken away whenever possible. In the fully equipped gardens a sowing of Lettuce Little Black Gott should be made on the 1st of the month, to be grown on a hotbed in November as described below. From the 6th of this month the sowing of all the varieties of Lettuces for the following spring should be started. The first variety sown should be the Little Black Gott, while the second batch should consist of the three varieties of Cos Lettuce: first, Green Flat of Paris; second, Grey of Paris; and third, Hardy White of Paris; and the last batch of first, Passion, and second, Palatine. All these varieties should be sown 450 seeds per cloche. The soil must be in good condition at the time and be kept fairly damp by spreading mats on the cloches in the middle of the day if the sun is too hot. In ordinary time the sowing bed is sufficiently damp for the germination of

the seeds, and we always avoid watering if possible; but we have known occasions when we have had to infringe the rule by watering the beds. This is only resorted to in very hot weather. The seeds of the Lettuces should be sown at an interval of twenty-four hours over a period of a fortnight, to prevent them from being ready together. The ground prepared in September must be well raked over and topdressed with a good coat of finely-decayed manure or sifted soil, which should be levelled and pressed down before setting the cloches in beds of three rows and forty-two in a row. When the number of cloches is limited, frames and lights may be used for the purpose; in this case they will be prepared for the pricking-off of the Passion and Palatine Lettuces, hardier and quicker growers. As soon as the seeds have produced their cotyledons and are big enough to be handled, the seedlings should be pricked off twenty-four to thirty per cloche; when transplanting care must be taken to keep the outside plants an inch within the edge of the cloches, as these plants may later on touch the glass and get damaged by the frost. This work being tedious and slow, it must be done whenever possible, and all other work suspended for this purpose, especially when a large number of plants is needed.

Carrots.

Carrots sown in July on the old manure-beds will be ready for market early this month. They should be pulled out to clear the ground for pricking off the Ox-heart Cabbages. The batch of Carrots sown in August will require some watering this month if the weather is fine. The ground should also be kept very clean to obtain a good crop during the winter months.

Celery.

The main batch of Celery will require heavy watering during October, as the plants will double their size in that month if well watered. The Celery Chemin covered in September will be ready early in October. When a constant supply is required to form a succession another lot can be covered to bleach.

Cauliflowers.

The last Cauliflowers will be dispatched to market early this month, before those grown in the fields are sent in. The varieties grown under this system cannot stand the cool and changeable weather, and, as a rule, keep very badly. The young plants sown in September will be ready for pricking in frames about the 10th of the month, 225 to 250 plants per light. The plants should be kept closed for eight or ten days; after this time they may receive some ventilation. A batch may be sown early in October under the lights, but this is only done when the batch in September has not done well, or when a large number of plants is required.

Ox-Heart Cabbages.

Cabbages sown at the end of August will have developed the first leaf and should be pricked off on an old manure-bed—generally where the carrots were grown late in the season. They should be pricked off 3in. apart. These Cabbages must be planted as deeply as possible, in order to induce the growth of young roots on the stem and to strengthen the collar. All degenerate specimens must be eliminated.

Beans.

Plants will be in bloom very early in October and the lights ought to be placed on the frames, leaving ample ventilation day and night wherever possible. Beans are very sensitive to frost, and the mats must be spread when needed. Picking may commence late in October, but at that period of the year the Beans will not get hard, and it is preferable to wait till November.

Chicory.

These plants will require no attention till the end of the month, when the leaves will have decayed and should be removed with the rake.

Strawberries.

The plants must now be in their winter quarters and covered with lights, which should be kept open day and night when it is not freezing. The only precaution needed is to avoid extra dampness at the roots.

Cardoons.

Where this vegetable is grown the plants must be tied up to bleach. When the variety grown is thorny, like the Violet de Tours, it is rather a difficult task; we get over the work by using two pieces of wood as handles with a piece of strong string between the sticks. By passing the sticks around the plants the leaves can be gathered together by twisting them. The leaves should be wrapped with straw or hay. When the weather is genial the plants should be left in the ground, but when frost sets in they must be brought into a cellar and the roots plunged in sand or

good soil. If the place is very dark the wrapper may be taken off.

General Work.

The season of heavy digging commences this month. Any improvements or alterations in the garden must also be carried out, in order to have time to get all the important work done during the winter. Trenches where the Melons were grown should be emptied. The manure of one trench should be put on the ground, to be evenly spread and dug in later on. The manure from the other trenches should be carted away to where it is needed. The ground for the final planting of the Ox-heart Cabbages must be prepared in a sheltered part (chiefly in the Costieres). A heavy manuring will be needed for a good result. The manure from the old hotbeds should be prepared for the following spring during October, as follows:— The four outside paths and the first old bed should be carted away. When this is done, the plot should be divided thus: first, on the east side, perpendicularly to the original position of the bed, one width of 4ft. should be carted away; second, one width of 9ft. should be left on the spot; third, one width of 4ft. should be carted away; fourth, one width of 9ft. should be left again, to continue with another band of 4ft. to the end of the plot. The width of 4ft. carted away represents the surplus of manure available for other parts of the garden, and the bands of 9ft. will form the soil to put in the frames the following spring. What is left on the ground should be forked and well broken up twice and placed in ridges. Part of the manure for the making of the hotbeds the following January will be received this month, and should be

stacked as is explained in another chapter (see page 24). Half of the supply for the spring ought to be on the ground in October, to be in good condition when it is required. All the frames, lights, and mats must be ready and in good order by the end of this month.

NOVEMBER.

Endive.

All the Endives must be cleared off the ground early this month, unless they are placed in the frames, as the leaves get spotted by the damp and cold. The Batavian Green will look well in the beds during this month if they are sheltered from the frost. A first batch may be bleached for consumption by spreading mats on them or by lifting the plants and setting them in a dark shed. They may also be tied up, but this plan is rarely resorted to at this time on account of the bad weather.

Lettuces.

The pricking-off of the Lettuces must be finished early this month. We generally prick off the Lettuce Passion and Palatine last of all. The Lettuces planted in September will be ready for market in the middle of November, and the cloches under which they were grown can be utilised for the second pricking-off of the Cos Lettuces. If all the young plants under the cloches are doing well they should receive some ventilation, to harden them in case of severe frosts later on in the season. Cos Lettuce require more room from the middle of November. They should be pricked off the second time fourteen per cloche and the plants kept close for a few days after which some

ventilation may be given when the weather permits. Ventilation is a very important detail in the culture of the Lettuces during November. They must be hardened to stand against the frosts later on in the season, but if air is given too liberally they are liable to be infested with the "Mildew."

The first forcing of Cabbage Lettuce Little Black Gott starts in some gardens in the middle of November. The hotbeds should be made where it is intended to force the Cos Lettuces under the cloches at the end of the following January, as at that time the manure used in November will be turned over and utilised again for that purpose. This manure must be very long and very dry to prevent the possibility of damping-off of the Lettuces occurring under the lights. The beds should be 18in. thick when trodden down; the frames should be set straight and level, and each one should contain six barrows of dry soil. The lights should be put on the frames and kept closed. When fermentation of the manure has begun, the Lettuces which were sown on the 1st of October should be pricked off thirty-six plants per light. The Lettuces should be kept very clean, and manure should be brought round the frames to keep up the temperature. The greatest care must be taken to prevent dampness, by spreading the mats at night only in case of frost, and if the beds are very warm it will be advantageous not to cover the lights at night if the frost is not likely to exceed two or three degrees. This method of cultivation is not much practised, as it requires a sound experience and the return hardly pays the expenses, but it is done chiefly to have all the manure and the soil on the ground ready for a period when the work is at a high pressure.

Ox-Heart Cabbage.

These Cabbages should be planted in the middle of November on the ground prepared in October. They should be planted in drills 3in. deep and 18in. apart each way. The plants must be thoroughly examined prior to planting, and all bad specimens rejected. They should be set very deeply, to protect the collar against the frost.

Cauliflowers.

If the weather is mild Cauliflowers must receive ample ventilation day and night; if they grow too rapidly, which is often the case, the lights should be set on bricks to establish a draught.

Celery.

At the end of this month some Celery should be lifted from the ground and set in frames (for this purpose we use two frames one on the top of the other). They should be covered with lights and receive ventilation to prevent the decay of the leaves. This batch should be kept for a supply after Christmas.

Beans.

This crop will be ready this month. They should be picked twice at an interval of a fortnight. When picking the first time light may be admitted by taking away part of the leaves. When possible ventilation should be afforded to prevent the decay of the younger pods.

Chicory.

The Chicory is lifted from the ground about the middle of the month and the roots placed in trenches

3ft. 6in. wide, allowing a space of 3in. or 4in. between each row. The roots should be covered 1in. deep with decayed manure or fine soil. If the soil is heavy clay, it is preferable to place the roots on the ground and to cover them with soil. If frame lights are placed over the roots they will serve to shelter them from rains. The forcing of Chicory roots at the earliest should not start till the end of the present month. Part of the bed should be covered with a layer of good manure, 15in. to 18in. thick, and also with mats. The crown will require four weeks to grow to a marketable size, and when a succession is wanted another part of the bed should be covered each week.

Strawberries.

Frames for forcing must be closed at night in November, and should the weather be too wet they should remain closed all the time.

Cardoons.

These must be brought into a cellar if this has not already been done. Some plants will be ready for market this month.

General Work.

Digging operations must be pushed very forward during the month if the weather permits to give to the ground all the benefit of the frost. The seeds for the following spring must be ordered at the first opportunity, care being taken in regard to the choice of the variety, the reliability of the strain, and the quality, or disappointment will follow. No more water being wanted till the end of January, the tank and the pipes should be emptied, to prevent frost from

causing damage. Opportunity may be taken to tar the tank after it is emptied. At the end of this month the new manure for the making of the hotbeds may be received. Great advantages accrue when it can be stacked for a few weeks, as it sweetens and all the Cryptogams grow out of it without any detriment to its quality.

DECEMBER.**Endive.**

The last Endives will be despatched to the market early this month, as they decay very quickly at this time of the year. The Batavian Green will be at their best in December, and if they are clean and healthy they may be kept for four or five more weeks if they are sheltered from the frost.

Lamb's Lettuce.

This salad is in great demand in December and onwards. The plants require no shelter during the frost, but they must not be picked when frozen or they will turn black.

Lettuces.

If the weather is genial the Lettuces under the cloches will grow well in December, and they may receive ventilation whenever possible. Slugs will do harm in some plantations; a visit early in the morning will repay the grower, as the pests are always on the glass inside, where they can be collected and destroyed. If there is any symptom of mildew the cloches or the lights containing the diseased plants must be kept closed. The plants may be sprayed with sulphate of copper in powder form. It is seldom that the plants

can be freed from this fungus, and the spraying is to prevent the mildew from spreading.

Some growers sow this month in frames and hotbeds seeds of Cos Lettuce Hardy White, and Cabbage Lettuce Palatine. This plan is resorted to, firstly, when the first sowing has not been very successful; and secondly, to form a succession to the batch sown in October. The plants sown this month are smaller, but are in very good condition when planting them out in March. Lettuces planted on hotbeds in the middle of November will require cleaning twice or thrice this month, according to the weather. This work must not be omitted, or the plants would soon decay. The paths between the frames must be filled with dry and long manure at least once in the month.

Carrots.

Carrots sown in August will be found useful this month. They can easily be sheltered with mats or straw spread over the beds in case of frost.

Celery.

Celery put in the frames last month will require cleaning in December. The lights must be kept open day and night if possible.

Chicory.

The forcing of this plant should be pushed forward this month and the first lot will be ready by Christmas. When picking the crown, the manure is taken out and the crowns are cut $\frac{1}{4}$ in. under the collar. They are tied in bunches, weighing 1lb. each. The roots may be thrown away after they have been forced.

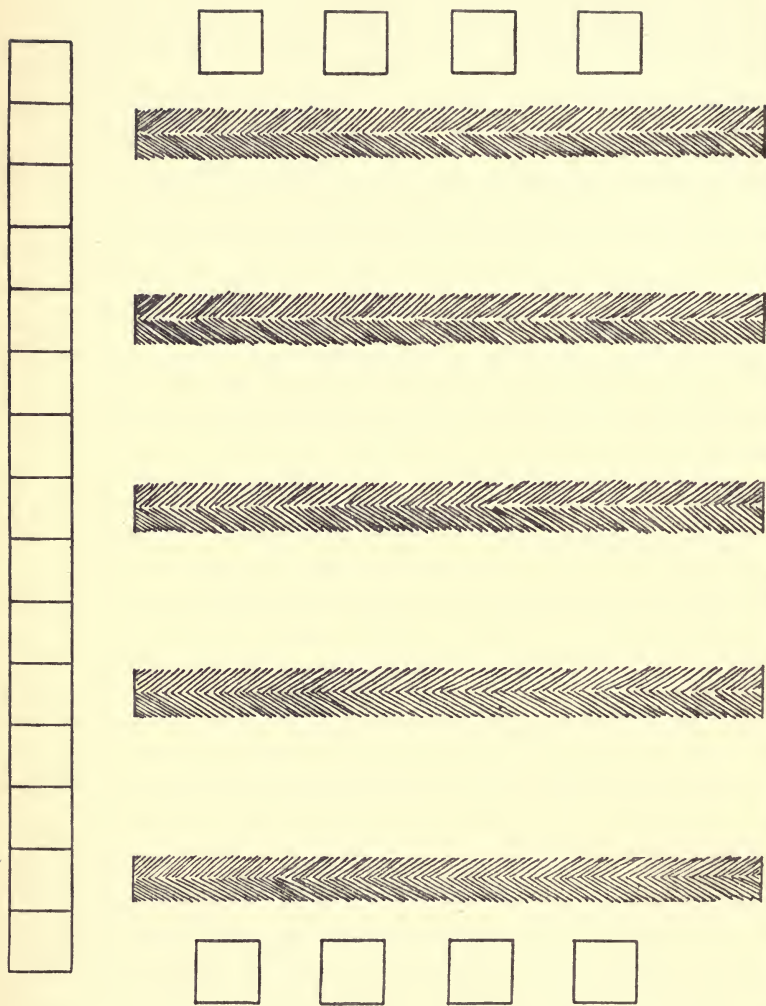

Fig. 14. The position of the five ridges of soil and the eight heaps of Lights when starting the making of Hotbeds.

General Work.

Any digging and alterations must be finished entirely by Christmas, because there will never be another opportunity for this work when once the making of the hotbeds is started. Where it is intended to force Lettuces without hot manure, frames should be set on the ground previously well prepared, leaving a path from 10in. to 12in. between each row of frames. We call this operation "Cold Work."

Two sorts of Lettuces are grown on the cold work: Passion and Little Gott. The present generation of gardeners prefer Passion to Little Gott, as the former can be planted earlier than the latter and does not require the shelter of the glass so long. But Little Gott has also staunch supporters, as it is always available when there is shortage in the market—in April, when it is too late for the hotbed Lettuces and too early for those grown in the open. The experience of the past seasons has, however, demonstrated that the Little Gott is more remunerative than White Passion, as this latter sort requires hearting in the open, and the removal of the glass early in April greatly impedes the growth for two or three weeks—a great loss at that time of the year. About Christmas the manure which has been collected before October should be brought first where the first hotbed will be, and secondly, between the ridges of the soil made in October. This manure should be spread all over the ground, to keep away the frost or to prevent the soil from getting too wet. The frames should also be brought where they will be needed, leaving the room for making the first hotbed (Fig. 14).

The lights will be brought out from the shed and set in heaps of thirty, made on the east and west sides

of the ground intended for the hotbeds. This will tend to reduce to a minimum the labour when making the hotbeds by allowing the work to proceed as speedily as possible, and to get a batch of produce ready at the same time, which is a great point in the rotation of crops. To make the hotbeds as quickly as possible is desirable, as the weather in January may force the cultivator to suspend work altogether for a time.

JANUARY.

Lettuces.

These are planted out in hotbeds as an intercrop among the Carrots, thirty-six to forty-two per light. Previously to this every plant should be carefully examined and cleaned and any doubtful specimens rejected. The Lettuces should only be planted in the hotbeds three or four days after they have been made—when the heat has dried the glass of the lights. When planting, care must be taken not to fix the Lettuces too deeply: the plants must swing freely when touching them with the fingers. If this precaution is not taken the bottom leaves soon decay, rendering the cleaning in February and March very difficult.

Early this month three barrow-loads of well-decayed manure should be put in each of the frames intended for cold work if the Lettuce Passion is to be grown, or six to nine barrow-loads for the Lettuce Little Black Gott. The lights should be next placed on the frames, giving a little ventilation if the weather permit. About the 20th of the month the Lettuces should be planted, after having been cleaned. Passion being a strong grower, twenty-five plants will be sufficient for every

light, but in the case of Little Gott thirty plants per light may be allowed. They should be kept very hardy, though they must be covered by mats in case of heavy frost.

In the "Costieres," plants of the Passion variety should also be planted at the end of January, 1oin. apart each way. The ground, which has been previously raked and levelled, should be covered with 2in. of well-decayed manure. The plants should be set in the ground deeper than those in the lights, to withstand the wind. It is important not to harden this batch previous to the planting: the check they receive when set is a safeguard against disease and frost.

Lettuce Passion grown in the early spring is not always very remunerative for the London markets, as the early batch of Cos Lettuces arrive about the same time. In the provinces they may, however, be grown very largely. There are two varieties—with brown and white leaves respectively. The latter strain is preferable. Cos Lettuces under the cloches will require a third transplanting as soon as some Cabbage Lettuces have been planted in the frames; five Cos Lettuces should be planted under each cloche; this operation tends to promote a very sturdy growth. When they are established in their new quarter a little ventilation may be given, increasing the amount with the growth and the fine weather. A sowing of Cabbage Lettuces All Year Round, or La Percheronne, also one of Cos Lettuce White Paris, can be made by sowing a few seeds of each sort among the carrots in the hotbeds early in January. If a large quantity is required a hotbed for three lights should be made for the purpose. When the plants are big

enough for handling they must be pricked off in a cold frame or under the cloches $1\frac{1}{2}$ in. apart each way. When a succession of saladings is required, a second sowing should be made at the end of January in a cold frame, the varieties being the same as those previously mentioned.

Radishes.

Radishes are a delicacy always in demand on the Paris market. Though there are many varieties, the *marâchers* only grow the Early French Breakfast all the year round. From a financial point of view Radishes grown on hotbeds as an intercrop are rather poor, as they are an impediment to the other crops. The French growers very rarely sow Radishes on hotbeds before the 15th of this month, as at that time the beds are no more than 14 in. high, and only give a mild heat. They should be sown very thinly—only 100 to 120 seeds per light—in the hotbeds prepared for the Carrots and Lettuces. If the beds are well built the Radishes will not require special care, but they will soon get drawn if too much fresh manure has been used. This can be stopped by giving a little ventilation. This is the reason why growers do not like to sow them among Lettuces and Carrots, as the Lettuces do not require any ventilation. An easy way to obtain them is to make a hotbed 6 in. thick and to cover it with 3 in. or 4 in. of well-decayed manure and sow the Radishes broadcast. The only precaution to be observed will be to cover the bed with mats in case of frost. They should be sown as an intercrop in the cold frames where the Lettuces Little Black Gott and Passion are grown. They do well with these plants, which receive ventilation when the weather

permits. They should also be sown in the "Cos-tieres" before planting the Lettuce Passion in the open. These different sowings form a complete succession of Radishes from the middle of February till the middle of May.

Carrots.

These should be sown as the main crop in the hot-beds as soon as these are made. The only variety grown is the Early Round Parisian. It is very important to sow the seeds thinly—200 to 250 seeds per light—in order to save the thinning operation, which is very tedious work later in the season, and also because when pulling out the surplus one is liable to disturb the young plants left to form the crop. When a garden is well situated, a sowing may be made in a cold frame at the end of January; the ground must have previously been well prepared. The variety sown is Bellot, very early and of medium size.

Cauliflowers.

Cauliflowers sown in September and pricked off in October must receive, when the weather permits, ample ventilation, and be sheltered only in case of severe frost. If the growth is too forward they can be pulled up and transplanted again in the same place, but if the growth is poor they will have to be kept close for some time.

Strawberries.

A first batch of plants should be started this month for fruiting. A hotbed—half hot manure, half dry manure or leaves—should be made about 18in. thick.

When the frames have been set a barrow-load of soil should be put in every light and the bed should be covered at night with mats. When the heat is slightly going down, the plants should be plunged into the soil, which should be brought level with the rim of the pot in which they have been planted, according to directions given on p. 128. Forty-five plants per light are sufficient. Previous to the setting the plants should be thoroughly cleansed and the top soil replaced with fresh, mixed with a small proportion of bone-meal—one pint to a barrow load of soil. The plants should be kept close for a few days unless the heat is over 50deg. Fahr., when gentle ventilation may be afforded. The covering at night is essential. If the heat goes down to 40degs. Fahr. fresh manure must be brought between the frames, in order to raise the temperature. The dampness of the ground and of the manure is sufficient for the starting of the growth of strawberries at least for a fortnight, when the watering may be carefully done with tepid water.

General Work.

January is responsible for the failure as well as the success of the whole year's operations. The making of the hotbeds for frames and the planting of cold work, upon which depend the good management of the working of the material, is in progress from the middle of this month. The amount of time required for these operations is very limited, and as ample allowance must be made for the weather, often unfavourable, the cultivator must have prepared everything beforehand, so as to minimise the labour.

Where the lights intended for hotbeds do not exceed 150 in number one bed may be made each day,

but when this number is exceeded not less than two beds should be laid down daily. The frames for cold work ought to have been laid down late in December, the ground levelled, and a crop of Radishes sown this month. The Lettuces should be planted in them during the last fortnight whenever time and weather permit.

Ground intended for early crops must be dug and thoroughly prepared this month, so as to allow of the setting of seeds and plants as early as possible in February. A good grower always gets everything in readiness beforehand, so as to take advantage of his opportunities for an early production. The cloche-beds where the Lettuce plants have been grown, also the hotbeds and the cold work, all require to be covered on every frosty night. The weather must constantly enter into the cultivator's consideration, as unnecessary covering is as harmful to the crops as no shelter, to say nothing of the cost of extra labour. All packing material, paper, labels, empties, &c., must be in stock late this month, to avoid trouble and waste of time when the crops are ready. All the manure necessary for the spring work must also be in hand, and, where there is not a regular supply coming in, arrangements for the quantity needed for the Melons must be contemplated from now, as it is always more advantageous to have it some time beforehand. The amount required for each melon-bed of fifteen lights is about three tons.

FEBRUARY.

Lettuces.

The planting of Lettuces under the lights on the hotbeds and in the cold frames should be pushed for-

ward so as to start the making of hotbeds for cloches in the middle of this month. The Lettuces set early in January will have grown, and care must be taken to clean them whenever the weather permits. The Cos Lettuces and Cabbage Lettuces sown in January will require pricking off in frames or under cloches. The latter are more suitable, especially when this batch is wanted late in March. They should be pricked off 140 to 150 per light or twenty-four per cloche.

When a batch of Cos Lettuces has been sown on hotbeds in December they will require a second pricking off at the end of February, to obtain good sturdy plants when planting in the open at the end of March. The Cabbage Lettuce Passion or Palatine sown at the same period will require ample ventilation whenever possible.

As soon as the hotbeds for the frames are completed, the hotbeds for cloches should be started for forcing the Cos Lettuces sown in October. A few years back special hotbeds containing three rows of cloches were prepared for this culture, space being left between two beds for the path. This system has, however, been abandoned, and the beds are now made next to one another as for the frames. The Cos Lettuces require a very mild and constant heat; therefore the hotbeds should be formed of one-third fresh manure and two-thirds dry manure. The beds need not exceed 9 in. in depth when finally trodden down. The necessary soil should be placed on the bed in ridges till the adjoining bed is finished before levelling it. When this is completed, short and broken manure is placed in the pathway to the level of the soil to prevent the latter from becoming displaced. A line

should be placed to mark the position of the outside row of cloches, which should be placed at a distance of 1in. apart. The second row should be placed likewise, and the cloches of the third row alternate with those of the second. Three or four days after the cloches have been placed in their position, one Cos Lettuce Green Flat of Paris should be planted in the centre of the bell-glass, with three Cabbage Lettuces in a triangle around it. After these have been planted

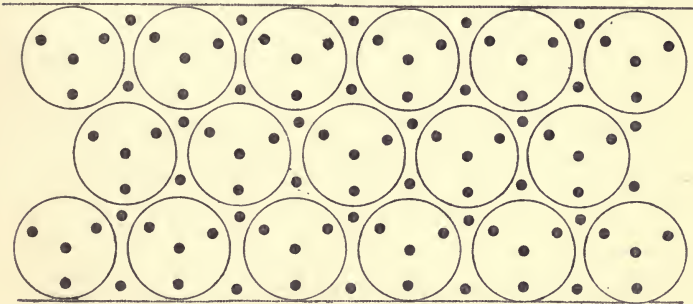

Fig. 15. Forcing Cos Lettuce.

Arrangement of the Cloches, 1st position (February).

another Cos Lettuce should be set in the angles of the cloches, as shown in Fig. 15. A small aperture for admitting fresh air to the cloche is made by pressing the soil in one spot just under the rim of the glass with the closed fist.

Cold work under cloches is not generally practised where manure can be had at a reasonable charge. When such is not the case it must be done as follows:—First: The ground having been previously well manured and prepared, beds of 4ft. 6in. should be marked out. Before placing the cloches, seeds of Radish Early Breakfast should be sown broadcast,

then the cloches should be set in three rows on each bed angle-wise. Secondly: Lettuce Little Gott and one Cos Lettuce in the centre should be placed under each cloche. Another method is to sow broadcast seeds of Carrot Bellot, and after the cloches are placed on the beds two Lettuces White Passion should be planted under each cloche. A fortnight later a Cos Lettuce should be set in the centre, as the Passion Lettuce will remain in the ground a fortnight longer than the variety Little Gott. The Passion Lettuce does well under the cloches providing it receives ample ventilation. When a succession of Lettuces is required, another batch should be sown in February in a cold frame. The varieties for this season are Cos Lettuce White of Versailles and Cabbage Lettuce La Percheronne.

Endive.

The first sowing of this salading should be made in the middle of February. A bed made with three-quarters good hot manure and one-fourth of dry manure should be prepared a few days previously. When the fermentation begins the seeds should be sown broadcast and thickly, the variety for this batch being La Parisienne or La Rouennaise, the latter being a little coarser and bigger than the former. The seeds should be covered very slightly—certain growers simply leave the mats till the germination begins. The seedlings should appear within two or three days. If they do not it would be preferable to make a thicker bed and insert another batch of seeds instead of waiting for the first lot to germinate, as when the seeds take more than four days to germinate they never give favourable results later on. At the

end of the month fresh manure must be brought round the frames to maintain the temperature, and a little ventilation may be given in the middle of the day when weather permits. This culture is difficult and must receive all necessary attention; it is only done in small gardens when there is time to attend to it thoroughly.

Celery.

The first batch of early Celery—Chemin—may be inserted in the middle of February on a good bed. The seeds must be reliable, as the germination is very slow. This crop is not very profitable as a market product, as it is ready early in August when there is very little demand. It also requires special attention and is only undertaken when there is ample time to devote to it.

Carrots.

Carrots sown on the hotbeds in January will germinate early this month; they require no special attention whilst the Radishes and Lettuces are in the lights. Old gardeners are chary about sowing Carrots on the hotbeds for cloches; but when the Cos Lettuces are good and sturdy insertion of a few Bellot Carrot seeds will give with some extra care a profitable catch-crop. We should not advocate the sowing of the above crop in the first year's working of a garden as weeds would greatly impede the growth, the elimination of which would hardly repay the cost of labour expended. In well situated gardens a batch of Bellot Carrot—a very early variety and with a medium size root—should be sown in the open, the ground having been previously well prepared.

Radishes.

This succulent vegetable is always grown as an intercrop among Carrots and Lettuces, either sown on hotbeds or in the open. When sowing Radishes as an intercrop among the Cos Lettuces, the variety National is preferable. It is of quite recent introduction and has become a great favourite among growers. It is of round shape, white tipped, medium size, and remains firm longer than any other variety. When sown early in the open they must be sown very thickly as the birds are, at this time of the year, eagerly seeking food of that description and frequently take a heavy toll of the seeds.

Cabbages.

A batch of Cabbage—Ox-heart or Early of Etampes—may be sown on the hotbed among the Carrots, to be pricked off in cold frames as soon as the cotyledons are well developed.

Cauliflowers.

A batch of Cauliflower Driancourt should be sown on a hotbed made up of half hot manure and half dry manure in the first days of the month. They should be sown thinly, and as soon as the seedlings appear they must receive ventilation whenever possible. The batch sown in September will be grown very hardy during this month if they are planted late in March. When the hotbeds for Lettuces and Carrots have been made early in January a lot of Cauliflowers may be planted among them late in February, four plants per light. The plants should be set very deeply and made firm at the roots.

Melons.

When there are a few frames and lights to spare, or when the Lettuce Passion has been planted in cold frames late in January, a batch of Melons may be inserted in the middle of the month, so as to have plants ready for setting out early in April in the frames where the Lettuces Passion have been grown. A bed consisting of three-fourths hot manure and one-fourth dry manure should be built up very carefully in a well sheltered place. The bed must be 18in. thick when trodden down. Some fine soil should be placed in the frame and the light kept covered with two or three mats. When the heat is about 72deg. Fahr., the seeds should be inserted one inch apart each way in a tray of fine loam; this should be plunged in the soil of the frame. The variety sown is the Little Parisian Prescott. Germination takes from six to eight days. The mats must be taken away at daytime, and a little ventilation may be given half an hour daily to sweeten the atmosphere and strengthen the plants. Much trouble and disappointment will be spared when a greenhouse is available in which to sow the seeds. They should be inserted in trays covered with a pane of glass. When the soil is sufficiently moist at sowing, the germination at this time of the year will take place without any other watering.

Strawberries.

Another batch of plants should be started this month as has been explained in the paragraph for January. The plants set in January will have started their growth: the temperature should be kept up by bringing fresh manure round the frames. They will

not require watering this month : the dampness of the beds and of the outside will be amply sufficient for their needs. On every bright day ventilation should be given to obtain a sturdy growth of the floral stem. The plants must also be kept clean, and it will be necessary to look through them and to remove the old decayed leaves, and also the "blind" parts, if any.

General Work.

The making of the hotbeds will require the attention of the gardeners all this month, and should the weather be favourable this work must be pushed very forward. The numerous sowings will want great care to give them air or to bring fresh manure round the frames to keep up the temperature. The mats will be all brought out this month. All the seedlings and young plants should be covered at night, but the beds of Carrots and Lettuces will only require sheltering in case of frost. When the mats are dry they should be rolled and left at the top of the lights until required again, but they must be spread out when they are wet to get dry, or they soon wear out; moreover, they are not such a good shelter when wet. Whenever the weather and time permit, Lettuces in the frames will want cleaning at least twice during their growth on the hotbeds. The ground for the open crop must be levelled and ready to receive the young plants or the seeds whenever the weather is favourable for such work.

MARCH.**Lettuces.**

Cabbage Lettuces when planted early in January will be marketable this month. They should be cut level

with the ground and packed in hampers, head downwards, so as not to soil the leaves, and be carried to the shed for the packing. If the weather is dry they will require a slight watering, which must be done with great care at this time of the year. All the Cabbage Lettuce, Passion or Palatine must be planted by the first week of this month. The birds will be found very troublesome and playing havoc with the fresh green leaves. Lettuce Passion and Little Black Gott grown under cold frames will require air whenever possible, especially the former, which is very hardy. Cos Lettuces grown under the cloches will require careful attention during this month. The mats must be spread when the sun shines brightly, and again when the thermometer falls to the freezing-point. Experienced growers only spread the mats when the bell-glasses turn white with the frost, and take them away as soon as the glass is thawed. This method gives a crispness to the leaves but requires a lot of attention, as very often this has to be done during the night. To save trouble of shading with mats, certain growers prefer shading with limewash; this saves labour, but is harmful to the growth of the plants should the weather prove dull.

Cos Lettuce is very difficult to force, and good results will only be obtained when the plants receive sufficient heat to push their growth. The attention and culture given must be such as to correspond as closely as possible with the natural conditions obtaining when they are grown in the open.

Cos Lettuce White of Paris should be set in the open, 18in. apart, in rich ground, from the middle of the month. Four rows of Cos Lettuces should be set at equal distance between the cloches on

the cold work. This will form a succession to the Cos Lettuces planted under them in the early part of March.

Onions.

Onions planted in September will require hoeing and cleaning. When the culture is on a large scale part of the sowing should be left in the seed-bed and pricked out this month, to form a succession to the batch planted out before the winter.

Endive.

The batch sown last month will be pricked off (180 plants per light) on a hotbed gin. thick when trodden down. The plants should be set when the first normal leaf begins to grow. The temperature must be very even and the lights kept closed for eight to ten days, care being taken to shade the plants when necessary. Other sowings may be made this month in the melon-beds and pricked off four weeks after the insertion of the seeds.

Carrots.

Carrots sown on the hotbeds in January will have developed two leaves, and care must be taken to remove the Lettuces in time to prevent the Carrots from getting "drawn." As soon as the Carrots occupy the whole space in the frames they must be thinned out and weeded. Some very finely-sifted soil should be spread to cover the collar of the young Carrots, in order that they may retain the red colour so much appreciated. After this operation a good watering must be given to wash the foliage and make the soil firm at the roots. A batch should be sown

early in March in the open in deeply dug ground. The best sorts for this sowing are either Bellot or Chatenay.

Cauliflowers.

The batch sown in September should be pricked off among the Carrots in the middle of March, four plants per light. The plants should be set very deeply and the soil made firm at the roots. When the plants are weak they may be planted sooner, and the reverse when they are very strong or when the Carrots are not well established. Cauliflowers may also be planted among the Lettuces grown in the cold frames in the way already explained. The batch sown in February should receive ample ventilation whenever possible. The watering should be moderate, to prevent conditions often favourable to Black Leg on the stem, and to harden the plants. Parisian growers do not prick out the spring-sown Cauliflowers, but the unsettled weather in England during March often tends to the appearance of the disease already mentioned, and it will repay the English cultivator to prick out the batch sown on hotbeds in February into cold frames, 200 per light, or under the cloche, twenty per cloche. About the middle of the month a second sowing of Cauliflowers should be made in a cold frame. The best variety at this time is Lenormand. This sowing should be made at the end of April among the first batches of Lettuces grown in the open.

Celery.

The main batch of seeds should be inserted late this month in a hotbed 6in. thick and well trodden down. Many growers only sow this batch and grow two

varieties: Chemin for early and Long Green of Paris for late supplies. In France they also sow a batch of Celeriac Little Parisian Improved. This deserves to be widely known, as it is a succulent vegetable during the winter either as a salading or cooked. It is an excellent keeper, and when the roots are clamped like mangels or swedes in the fields they can easily be kept till the following March. The seeds should be sown thinly and slightly covered. Germination is very slow, and the mats should be kept on all day, especially during bad weather. As soon as the young plants get through the ground, a little ventilation should be given every day, to prevent damping off.

Cabbages.

Ox-heart Cabbages planted out in November will require hoeing and cleaning as soon as the ground is dry. The soil, too, should be brought round the stems to keep the roots moist. They may also want watering, which must be done early in the morning. Plants from seeds sown early in February should be set out 18in. apart each way in good ground.

Melons.

Plants from seed sown in the middle of February should be potted in "sixties" about the 8th of the month in good loamy soil; the plants must not be pressed hard on the roots, and the pot should be filled to the rim to prevent the extra dampness at the roots. The pots must be plunged in a good hotbed 18in. thick and manure brought level to the top of the frames outside. The fermentation of the manure must be well started before placing the plants in the frames.

The main batch of Melons to be planted in the frames where the Carrots were grown should be sown between the 15th and the 31st of the month. It is not advisable to insert seeds after the latter date, especially in England, as the fruits coming from these plants would never give satisfactory results. This sowing is done as is explained in the special chapter devoted to this fruit. To avoid disappointment, it is advisable to sow double the quantity of seeds that is necessary, with an interval of forty-eight hours between each sowing.

Cardoons.

This winter vegetable should be sown this month. Three seeds should be placed in a "sixty" pot and placed at the top of a frame where Melons are grown. When the seedlings appear, one should be kept per pot and be placed in a cooler frame.

Strawberries.

Plants started in February will require ventilation during the present month and to be watered according to their growth and the state of the weather. They must be kept rather dry till the floral stem appears. The last batch of plants should be started at the beginning of March. A bed 10in. thick should be prepared and the frames filled with two barrow-loads per light of a good rich compost. The plants should be taken out of the pot and set forty-five per light directly in the soil when this is warmed through. Care must be taken to keep the plants dry; they may be sprayed with some water if the sun shines brightly. Ventilation may be given as soon as the plants throw a new crown. This batch when well grown gives very good results, and the fruits are well flavoured.

Tomatoes.

Tomatoes are sown at the beginning of March on a medium hotbed. There are so many good sorts that it would be unwise to name the variety. The best cropper, the hardiest grower, and the one giving the best-shaped fruits should be chosen. About the 25th the plants should be pricked off—250 per light—on a bed where other crops have previously been grown, after the manure has been turned over and the frames and soil have been replaced in their original position. Ventilation should be given as soon as the plants are well established. The mats must be spread at night to prevent a check, so prejudicial later in the season.

Turnips.

French growers grow either Turnips or Carrots on the hotbeds, but it is advisable to cultivate these two vegetables in England to facilitate the marketing of both. When it is intended to force Turnips in frames, a batch of Lettuces is grown on the hotbeds in January and marketed early this month, leaving the frames at liberty for the Turnips. This vegetable requires a very mild heat, and does better on a spent bed. The soil in the frames is raked over and pressed down lightly. The variety grown for this purpose is Turnip Long White or Milan Round Flat. It should be sown in rows, eleven rows to each light, and three seeds should be dropped together at an interval of 3in. in the row. The lights should be kept closed till the cotyledons come through the ground. Ventilation should be given gradually, as the weather permits, day and night if possible. Light waterings should be given when necessary. At the end of this month, when some frames and lights are at liberty, they should be set

on good ground and a batch of Turnips—Croissy White or White Hammer—should be sown as already mentioned for hotbeds. This batch in cold frames will form a succession to these from the hotbeds.

General Work.

During the present month the attention of the gardeners will be necessary in every part of the ground. The hotbeds must be constantly visited and no trouble must be spared in any detail to obtain favourable results. Ventilation, watering, and shading must be given and attended to at the proper time. The cleaning of the plants under lights must be done in a thorough manner, as dampness is prevalent in dull weather. The packing of the Radishes and Lettuces must be done very carefully and quickly, as time is precious, while the planting and sowing in the open must be pushed forward so as to get the crops as early as possible.

APRIL.**Lettuces.**

Cabbage Lettuces planted on the hotbeds must be marketed as soon as possible, to make room for the Carrots and the Cauliflowers. Those grown under cloches will also be ready in an ordinary season about the 10th of the month. When well grown they should be of an exceptional quality and well hearted. The Passion Lettuces in cold frames can be left growing in the open early in April by taking away the frames and lights which are generally used for the first batch of Melons. The Little Black Gott Lettuces also grown in cold frames will require ample ventilation in the daytime; but the lights must remain on the

plants till they are ready for market. Care must be taken to guard against late frosts, and the lights or cloches must be covered at night when necessary, as the frost will cause the leaves to be spotted, and this will only be noticed a few days after the frost. The planting of Cabbage Lettuces sown in January should be done early this month if the plants are of a good size. They should be planted by themselves 9in. apart each way, or as an intercrop among Cos Lettuces

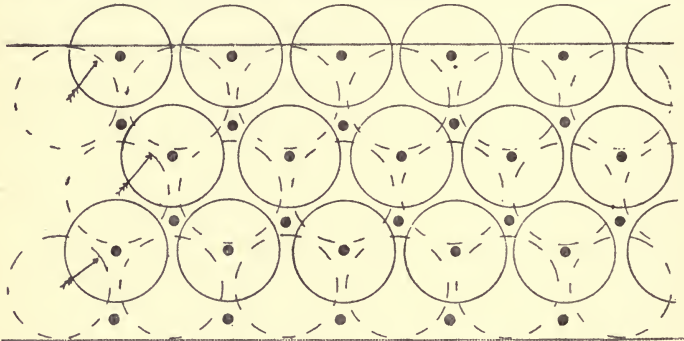

Fig. 16. Forcing Cos Lettuce.

Arrangement of the Cloches, 2nd position (April).

or Cauliflowers. It is customary to sow some Radishes or Spinach before planting Lettuces, as these crops are ready for market before the Lettuces require the room. The Cos Lettuces in the cloches will require great care this month. When the plants are of a good size in February they may be marketed in the middle of this month. They should be tied the day before pulling to keep the leaves together and to avoid breakages when packing. This batch should be pulled all together, good and bad plants, and the cloches should be removed on the 1st, 4th, and 7th row of Cos Lettuces as soon as possible (Fig. 16).

When this second batch is well forward, and when the weather permits, the plants will require a good watering, which will still further hasten the growth and allow the second removal of the cloches on the third batch, which will get full benefit of the shelter of the bell-glass, as sometimes this third lot forms a heart before the second removal of the cloches. Particular attention must be given to the shading this month, as the plants are very tender and are soon scorched. The planting of the Cos Lettuces must be done in the open very early this month, the plants having been sown in October or December. The plants sown in January can be put in later in the month 18in. apart each way.

Onions.

The ground must be stirred by a careful hoeing early this month. When the soil is in good condition Cauliflowers are planted as an intercrop among the Onions—five rows in a full size bed and 11ft. wide. This crop must be very early to be remunerative, and it may be necessary in light land to water it twice or thrice during the month. In sheltered corners some Onions may be ready late this month, though it is preferable to wait till about the 10th of May, when the batch can be pulled all at once.

Endive.

Endive sown in February should be ready to be planted early in the month under lights (thirty-five plants per light) or four per cloche. The plants should be shaded and kept close till they are well established. Ventilation can be given gradually. The plants will also require light waterings. At the

end of this month the Endive can be safely planted in the open roin. apart. The ground must be damp when setting the plants, to avoid watering till they are well established. Another sowing can be made on a hotbed this month. The seeds must be sown very thinly, as the plants resulting therefrom are put out directly in the open four or five weeks after the sowing of the seeds. The only variety grown in the French garden till August is La Rouennaise.

Carrots.

Carrots on the hotbeds will require a thorough watering, 6galls. per light at two different times, as soon as the Lettuces are gone. They should be weeded and thinned in the middle of the month, and must receive ample ventilation day and night, especially in the last fortnight. The batch sown in the open will also require light and frequent waterings, more particularly in hard ground. In private gardens the main batch for the summer may be sown in April, the best varieties being La Chatenay and La Guerande. French growers do not sow any Carrots this month, as those grown in the field are plentiful in the summer.

Radishes.

When these are in constant demand, seeds can be inserted weekly among other crops. The plants require frequent watering to forward the growth and stop the development of the fibrous roots, which renders the Radishes pithy and strong.

Cauliflowers.

Cauliflowers planted among the Carrots will require no special care this month, except when the leaves

touch the glass; in this case the frames must be lifted to give more head-room. The planting in the open must be pushed very forward early this month. If some cloches are available they may be used in covering a few Cauliflowers planted outside. As soon as the first batch of Cos Lettuces are marketed from under the cloches, a Cauliflower should be set exactly in the place previously occupied by the Cos on the outside rows of the bed only. The plants used for this purpose were sown in February. Another sowing of Cauliflowers should be made this month to be ready to occupy the ground that carried the first batch of Cos Lettuces in the open. Cauliflowers do not require heavy watering in April. To obtain nice heads the plants must be kept hardy and form good stump and leaves, and this is only obtained by setting them in good ground and by keeping them rather dry before the showing of the bud.

Celery.

Plants sown in February may be pricked off in cold frames—140 plants per light. The plants must be kept close till well established, which will take from twelve to fifteen days. They must be shaded when the sun shines brightly. The main batch sown in March will require careful ventilation and watering in April, to avoid damping off. When a constant supply of this vegetable is needed, a sowing of the variety Red of Aylesbury, or Leicester Red, should be made in a cold frame or under cloches during this month. The Red varieties are better keepers than the White and the Green, to which they form a succession. Another sowing of Long Winter Green may be made early this month,

especially when the old manure-beds are not likely to be at liberty before the 20th July. It is preferable to work with late sowings of Celery, especially in light land, as early batches often run to seed.

Melons.

When the weather permits, the frames and lights from the Passion Lettuces should be used for the hot-beds of Melons, built as described in the special chapter devoted thereto. The Melons must be planted when the bed is sufficiently warm, and must be shaded for the first eight or ten days. If the ground is very dry when planting, the plants may be watered with tepid water. The main batch sown in March will require potting early in April. When the plants have been shifted, they must be sheltered from the hot sun. The youngest plants may receive gentle ventilation in the middle of the day whenever possible. Some growers insert a few more seeds early in April in case the earlier plants fail. As a rule this batch does not grow satisfactorily late in the season, and the fruits do not ripen well. As the weather in April is very changeable, the gardener will have to shade, to give air, and to shut the lights at frequent intervals of time. The mats must be spread at night very carefully, so as not to change the atmosphere under the lights.

Cardoons.

The plants will have developed their first leaf in April. One should be kept for every pot, and these should be put in a colder frame as the outside temperature is warmer. They will not require much watering this month to keep them clean and healthy.

Turnips sown in March in old manure-beds will

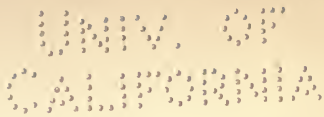

Calendar of Operations.

require thinning. One plant should be left for every three seeds that were put in. The ground must be kept sufficiently damp to prevent them from running to seed. Ventilation must be given freely, and when the weather is favourable the lights may be opened—one one way and the next the other side, to promote a draught. In good ground a batch may be sown in the open, broadcast if the ground is clean, and in drills when a lot of weeds are expected. The seed may want frequent and light waterings to keep the "fly" away. The first sowing of Turnips, especially in heavy land, is of precarious germination, and when the young leaves appear hard and of a pale green it is absolutely necessary to re-sow the beds a second time, or the first sowing would unavoidably go to seed.

Tomatoes.

The pricking-off of the young seedlings must be pushed forward. Ventilation should be given freely, according to the weather and the growth. At the end of the month the strongest plants may be lifted and planted at the rate of 100 per light in cold frames which have been filled with at least 6in. of soil.

Cabbages.

Ox-heart Cabbages planted in November will require ample watering, and in a favourable season they will have a nice heart at the end of the month.

Beans.

Though the constant and early importation of these from Jersey and Algeria prohibits their cultivation as a paying crop in England, it is, however, a useful one to grow, especially in the provinces. Early in

the month frames should be set on well dug ground where some other crops have been previously grown. The lights should be placed on the frames for at least a week to warm and dry the soil. When the ground is in good order, three rows of four holes each should be made at equal distances in every light, and six to eight beans of the varieties Little Nigra or Canadian Wonder should be placed in each hole. The seeds should be very lightly covered and the lights kept closed till the cotyledons are well developed, when moderate ventilation can be afforded, and increased with the growth. Another method is to sow from four to six beans in large "sixties," and to place them in the tomato-house to germinate. At the end of the month the plants should be set on a south border and covered with the cloche.

Strawberries.

The earliest batch forced in January or beginning of February will be fruiting this month. The plants must be watered frequently, and twice a week some liquid manure may be added to the water, increasing the proportion every time. When the fruits turn white the manuring must cease, and the ventilation should be increased till they are ready to pick. The batch planted direct in the frames in March will flower this month, and will require similar care to that given to the first lot. Some time this month the plants set outside in the autumn for runners will want hoeing and the application of a good mulch of heavy manure to stimulate their growth.

General Work.

The French garden is in full activity in April. The ground, except the portion left for the main batch of

Melons, will be occupied by different crops, which will require all the gardeners' attention.

The manure-beds will receive abundant watering and ample ventilation whenever the weather permits, and special care must be taken to avoid checking the growth, especially during showers or cold nights. The cloches will also claim attention by reason of the covering and uncovering with mats that will be entailed. Watering in the open may be necessary on a few occasions, but it must be borne in mind that the ground is still cold and damp, and gives sufficient moisture to the plants set in February or March. The sowings and the pricking-off of the numerous plants which will succeed those planted earlier, must be well attended to, to avoid disappointment and delay. Weeding will also be necessary, especially in the lights and cloches. The packing and despatch of the goods must be done, taking care first to collect the plants in the proper time to sell them to the best advantage; and, secondly, not to interfere with the other work in the garden.

MAY.

Lettuces.

The Passion and Little Black Gott Lettuces grown in the cold frames will be ready early this month. When they have been cleared off the ground the place must be hoed and raked for the benefit of the Cauliflowers. The Passion Lettuces grown in the open will also be ready from the 8th or 10th of the month, especially when the growth has been stimulated by a good hoeing and two or three waterings. The batch is generally ready within a week or ten days, and the grower who has a few thousands will do well to make

provision for their quick despatch to market, as they soon run to seed after hearting. Parisian growers sell their own produce, and when they notice a short supply of Lettuces on the market they despatch them very early—just when the heart is forming. Lettuces from the sowings made in January will require frequent waterings; they should form a succession to those sown in the autumn when well grown. The

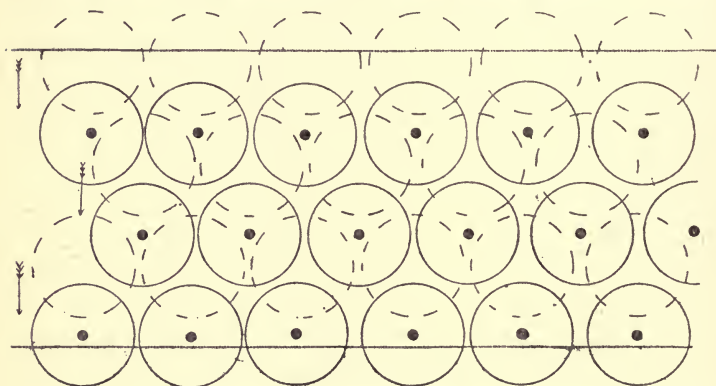

Fig. 17. Forcing Cos Lettuce.

Arrangement of the Cloches, 3rd position (May).

last Cos Lettuces under the cloches should be marketed by the 10th of the month. The grower must exercise considerable discretion in regard to the cutting of the second batch. Very often he has to cut it before they are well formed, so as to be able to shift the cloches from the 1st, 4th, and 7th rows to the 3rd, 6th, and 9th rows (Fig. 17).

As soon as the Cos Lettuces are gone, the ground should be hoed and cleaned for the crop of Cauliflowers, which will be a fair size by this time. The Cos Lettuces grown under the cloches in the cold work

are generally ready a few days before the third batch grown in the hotbeds. They generally form fine specimens, and, when they have received the necessary attention, prove a very remunerative crop. A great drawback to this system of cultivation under the cloches in the cold work is the frequent attacks of *Aphis* (Green or Black Fly). Unfortunately, hidden between the leaves, these pests are hardly noticeable. There is no remedy that can be applied without at the same time spoiling the Lettuces. The best preventive is ample ventilation, and shading when necessary.

Around Paris the growing of Lettuces is a very important industry, and constant sowings are made to have a succession. English growers are handicapped in this direction, as salads are not so popular as on the other side of the Channel; but in private places the gardeners will have to sow seeds of Cabbage Lettuces, which are always grown as an intercrop among Cos Lettuces or Cauliflowers. The sowings must be very thin and receive frequent and light waterings. The plants should be put out into their final quarter direct from the seed-bed. Varieties are very numerous, but *La Perichonne* and *La Batavia* are those chiefly grown, owing to their slowness in running to seed. The Cos Lettuces will require frequent waterings or they will soon go to seed. The best sort for summer work is *La Versaillaise*. To avoid the spotting of leaves, so prevalent during the summer, the plants must be watered early in the morning in time for the leaves to get dry before the sun gets too hot.

Endive.

Endives planted in the lights or under cloches may be safely grown in the open during this month. They

will require light waterings to prevent them from running to seed. Some plants may be tied up for blanching. At the end of the month a good watering should be given previous to this operation, and the moisture will then be sufficient till the plants are ready for market. The tying must be done as required, unless all the batch can be marketed at one time. Further sowings of La Rouennaise should be made in the beds where the Melons are planted, or in small hotbeds specially made for the purpose.

Carrots.

The Carrots on the hotbeds can be grown in the open by taking away the frames and lights which are used for the Melons. They will require very heavy waterings, as they are gross feeders, and they must be ready at the end of this month, to make room for the Cauliflowers. The batch sown in the open will require thinning and weeding whenever possible, and the ground must now be kept damp to avoid the cracking of the roots, which is caused by a drought followed by a heavy rain or watering. A sowing can be made this month where there is a constant demand for tender and young Carrots. The germination must be helped by light and frequent waterings. This batch is liable to the attacks of the Carrot Fly, so prevalent from the end of May. This explains the reason why this sowing is so seldom made.

Cauliflowers.

The batch planted among the Carrots will show bud early this month, and they will require ample waterings with the hose at least every two days. At the end of the month these Cauliflowers will have

developed some fair-sized heads; these must be carefully covered by leaves broken from the base of the plants, to keep the inflorescence white and smooth. The two batches of Cauliflowers planted either among the cold work or the cloches will require very little watering early in the month; but a careful inspection must be made of the growth and heavy waterings started as soon as the plants get a fair size. The planting of Cauliflowers may be continued in spare ground or among the Lettuce plantation. The setting must be made three weeks after the insertion of the Lettuces or Endives, or the Cauliflowers would overtake them in their growth and occupy all the room, with disastrous results.

An important sowing of Cauliflowers Driancourt or Lenormand must be made in a well prepared bed by the 10th of the month, to be transplanted in the Melons from 1st July. The seeds must be sown very thinly, and ample allowance must be made for good plants. At this time of the year, especially in light soil, the young plants in the seed-bed are liable to go "blind," and it is necessary to make the losses good. Some old growers attribute it to the larva of some insect, but the cause has yet to be ascertained.

When a small variety such as Little Solomon or Early London has been grown a few heads may be ready at the end of the month.

The cutting of Cauliflowers requires an experienced hand, for when cut too early the inflorescence withers very quickly, and when cut too late it breaks away and gets very coarse.

Celery.

Early in the month, where there are cloches or lights at liberty, the strongest plants may be pricked off

1½ in. apart under glass, in order to obtain an early batch for planting outside at the middle of June. At the end of the month the main batch should be pricked off 2 in. apart each way in spare old manure-beds where Melons and Endives were grown. If no ground is at liberty beds may be prepared for the purpose. A layer of 3 in. or 4 in. of decayed manure and 2 in. or 3 in. of soil, well raked and levelled, will be suitable. The beds must be in good condition when pricking-off is undertaken, and must be kept damp by spraying them once or twice daily, according to the weather.

The Celeriac may be pricked out early this month to obtain very good specimens, when setting the plants in their final quarter. This vegetable has also the advantage of not running to seed quickly.

It will not be too late to sow a few more seeds of late Celery early this month. This batch will produce fine specimens and is a good keeper when the weather is favourable to its growth in October. The batch sown in February and pricked out in April will be ready to be planted in its final quarter late this month. The Celery should be set very thickly in a heavily manured bed in the open, 10 in. to 12 in. apart each way. The plants must be well watered and the ground kept moist till they are well established.

Melons.

The making of hotbeds for the main batch of Melons, and their planting, will be the chief and most important work. Fresh manure must be had as the work proceeds, and this will want a good soaking when in position in the beds, to assist fermentation. The plants should be set whenever the heat has

warmed the soil; they must be shaded for at least eight or ten days, when ventilation may be given. The batch planted in April will grow well and form a quantity of wood, which will require thinning, as explained in the special chapter. Watering must be moderate until the female flowers are well set, when it may be given more freely. Ventilation should be given according to the weather and the growth. The mats must also be carefully spread at night so as to avoid any check to the growth.

Cardoons.

The plants must be gradually hardened off early in May for the final planting at the end of this month. Whenever possible the ground should be well dug and heavily manured. Holes should be made 2ft. 6in. to 3ft. apart each way and filled with garden refuse or ordinary manure, which should be covered with 4in. or 5in. of soil. At the end of the month the plants should be set and well watered in.

Turnips.

During the first days of the month the lights and frames may be removed from the Turnips and used for the Melons. The soil at the roots must be kept damp, otherwise the Turnips will not be tender. This batch is generally ready by the 15th of the month. Those grown in the open must be well watered and thinned out whenever necessary. In good ground the plants where crowded should be pulled as soon as possible after germination. Moreover, when the Turnips are ready, the biggest should be pulled out to give room for the smaller ones. This, when done in proper time, ensures a more profitable crop. Another sow-

ing of Turnips (New Model or Round Croissy) may be made early this month when there is a market for this vegetable in July. The germination of the seeds is very troublesome on account of the Turnip Fly. The seed-beds must be sprayed twice or thrice daily to induce a quick growth of the first leaves, when the plants will be free from the attacks of this beetle.

Tomatoes.

Very early this month the plants should be lifted and pricked off a second time—100 per light. When preparing the bed necessary for the extra room needed no fresh manure must be used, as in fermenting it would burn the roots. The plants should be set very deep and kept close and shaded for a few days. After this, ventilation should be increased gradually and left at night till the 15th of the month, when the lights may be removed altogether. The frames must be left so that the lights could be replaced in case of late frosts before the planting. The plants in the frames must not receive any water this month, especially when the soil is very rich; this will tend to harden them and to force the growth of the first truss.

The final planting should be made from the 15th of the month in sheltered positions, and earlier when the plants can be covered with bell-glasses. In the open field or in heavy ground this operation can be delayed for ten or twelve days. The plants should be set 18in. apart in the row and 2ft. between the rows. When there is a great number of plants to be put out it is usual for a man to open the ground with a spade whilst a boy slips the plants into the aperture. The soil should be made firm at the roots by pressing it

with the foot. More care and time may with advantage be taken when only a few plants are required by making a hole with a spade and bringing some loose soil round the roots. The ground must be very clean and well prepared previous to the planting. Tomatoes do better in firm, heavy ground; they require no stable manure. A sprinkling of basic slag or of potash will be found very beneficial. These manures must be in the ground a certain period before they can be assimilated by the plants; this enables the Tomatoes to form trusses of blossom before the plants receive any benefit from these dressings.

The tying of the Tomatoes is sometimes done on wire, running 12in. to 14in. over the row of plants. This system is cheap and quick, but unfortunately the plants must have been in the ground a certain time before they can be tied on the wire. Moreover, this operation must also be done within one week and at a time when the attention of the grower is needed all over the garden. The tying on bamboo canes is preferable, as the plants are thus secured when they have grown a few inches. The outlay may be greater, but these bamboo canes last many years. In staking the plants the canes are inclined row to row, and only one space between two rows is used as a path; this gives more room for going up and down with baskets when picking the fruits.

Cabbages.

The Ox-heart Cabbages must receive plenty of water in May. All of them ought to be despatched to market this month. When the ground is at liberty it will require heavy watering before preparing it for the insertion of another crop, as Cabbages tend to dry

the ground to such an extent as to make it unsuitable for a proper tilth until it has been well soaked.

Beans.

Beans sown in April will require ample ventilation during the daytime, while the necessary covering must be carefully done at night in case of frost. In genial weather the glass should be removed at the end of May, when the plants should receive a good hoeing. This crop does not require watering this month.

Chicory.

This salading, grown chiefly in Belgium, is a very good crop for the winter when bleached. It should be sown on a ground well manured and well prepared late this month. The best variety is Chicory Witloof. The seeds should be sown in drills 10 in. apart and covered with finely sifted soil. They will require some watering in case of dry weather. The only other care necessary will be to keep the ground clean. The plants should be thinned out 6 in. or 8 in. apart. The "thinnings" may be pricked out in bare places. In July or August the leaves will need trimming; only the outsides must, however, be cut. If the leaves were cut short the growth obtained when bleaching would consist of small narrow leaves and no heart.

Strawberries.

The plants will be fruiting freely this month and will require liquid manure twice weekly, which should be discontinued when the fruits change in colour. Ventilation must be given freely in the daytime when weather permits, and air may be left at night to pre-

vent the damping of the fruit. The plants set in the open for the runners must be well watered and kept clean. They will show buds, which must be removed, as no fruiting must be allowed on them. However, every plant growing blind—*viz.*, without any inflorescence—must be destroyed, as the runners obtained from such never produce fruit.

General Work.

This is the busiest month of the year in the French garden, and to be successful the work must be done methodically. The most important detail is the making of the beds and the planting of the Melons, which must be done in the shortest time. For this the gardener must have prepared everything necessary for the work in the last days of April—such as manure, fine soil, frame, and lights. The planting of saladings must be done with care, and preferably late in the evening or in dull weather, to prevent flagging. The watering work will greatly increase this month, and the importance of the perfect irrigation will be greatly appreciated and fully experienced at this period of the year. The ventilation and shading will also require careful attention. Packing, again, will be one of the chief items in the routine work—Saladings, Radishes, and Carrots will be ready. They should be despatched as soon as of suitable size, especially Saladings, which soon run to seed when left too long.

Apart from the making of the hotbeds for Melons, the work will be very light, but it must be done very quickly if everything is to receive attention at the proper time. We may give here the routine of a day's work in a business garden with three men and one woman packing.

One man is working all day at the making of the hotbeds for Melons, receiving the necessary help for carting of the manure, the shifting of the frames and lights when needed. The two men gather first thing in the morning the vegetables ready for market and bring them to the shed before 8 a.m. The uncovering of the lights and the ventilation are also done before 8 a.m.; from breakfast till 10.30 a man does the necessary watering and afterwards joins the other attending to the numerous crops. The woman packs all day and receives the necessary help for the tying of the hampers, labelling, &c., shortly before the dispatch of the goods.

JUNE.

Lettuces.

The spring batch of Cabbage Lettuce will have been cleared off the ground. When plants are needed for intercropping among the last crops on the hotbeds in July they can be sown four weeks before they are required. The best varieties are Batavia, Palatine, Perrichone, and All the Year Round. Seed should be sown very thinly in a spare bed in the open, and the ground kept damp by light and frequent waterings, early or late, but never in the middle of the day.

The Cos Lettuce White of Paris will be ready late in May and early in the present month. The soil must receive heavy waterings, to keep the plants tender and to prevent them from running prematurely to seed. A few plants must be examined inside the heart, which sometimes decays without indications appearing on the outside. When Cos Lettuces are to be grown as a main crop on the old hotbeds in July, they must be sown as was explained for the Cabbage Lettuce. The

best variety is Hardy White of Paris. The young plants must be thinned out to keep them in condition, hardy, and stumpy.

Endives.

Plants set out in April may be marketed early this month. When tying for bleaching the raffia must be left loose, as the heart gets bigger after the plants are tied. Another batch should be planted outside, allowing roin. each way. The most important item in their culture is the frequent and light watering. Endives should be grown as a main crop on the hotbeds in July. If it is sown in the open very thinly La Rouennaise is the best variety for the purpose. The seeds must be inserted very early this month. A few seeds of Endive La Ruffec may be sown this month for planting in the open ground among the early potatoes or by themselves.

The Endive Batavian Green should be also sown this month when it is intended to be planted in heavy ground. This salading is a very good doer, and is grown on a very large scale in France; but for quality the principal batch is sown in July. It is necessary to sow the Endive under glass till late in June, as these plants require a quick germination; they are liable to run to seed when sown in the open before that date.

Carrots.

Early this month the last Carrots will be ready for market. These must be pulled all at once, large and small, as those left would never give satisfactory results. As soon as the plants are lifted the ground should be cleared, hoed, and raked over for the benefit of the Cauliflowers. When Carrots have been sown

among the cloches they will require abundant watering early this month, as they should form a succession to those grown in the frames. The batch sown in the open will require ample watering at this time, especially if Cauliflowers have been grown amidst it as an intercrop.

Cauliflowers.

Cauliflowers planted in March either on hotbeds or in the open will be forming their inflorescence during June. They will require abundant waterings daily. When the Cauliflowers show the buds they must on no account get dry at the roots, or the buds will remain small and uneven. The inflorescence must be carefully shaded from the light to keep it white. For this purpose it is advisable to use the bottom leaves of the plants. The young plants in the seedling-beds must be kept very damp by light but frequent waterings. They must be pricked off when they are the proper size. This explains the reason for the frequent sowings. It is far better to destroy a batch of unsuitable plants at once than to keep them, as the loss is then restricted to a minimum.

Celery.

Plants set in store should now receive all the necessary waterings. "Fly" may attack the young Celery this month, and as soon as their presence is noted the affected leaves must be picked and burned. Further, the plants may be sprayed once a week—at night only—with paraffin and water—one 2in. potful in 3galls. of water.

A batch of Celery Chemin may be set at the end of June, 18in. apart. The plants must be watered in, but

though the ground must not go dry the watering must be done with care for at least four weeks after planting. Cabbage Lettuces and Endives may be planted and Radishes or Spinach may be sown as an intercrop.

Melons.

All the Melons will now be fruiting, a few of which will ripen at the end of the month. The plants must on no account get dry. A light watering daily is preferable. Care must, however, be taken to suspend the watering if the weather should get cold or dull. Ventilation can now be given freely whenever possible. The fruits will stop the growth of the wood to a certain extent, though it will be necessary to examine the plants and remove all extra growth.

The second batch planted from early in May will require ventilation daily; the watering is very important this month, as the plants must ripen the wood properly if good and sound fruit is to be obtained. The grower will have to pay all his attention to this item as some female flowers will be set during the last fortnight in June, and the watering must be done according to the stage of growth of the plants. In heavy ground the natural moisture before the setting would be practically sufficient, especially when the plants have been mulched. In case of storm the lights must be closed and mats spread at night as the Melons are liable to be attacked by *La Nhuile*, a predisposing cause of which is a brisk change in the temperature.

Cardoons.

The plants will now be well rooted and will require ample watering. At Gennervilliers, a suburb of

Paris, where they are grown chiefly, the ground is flooded at intervals. When the plants are allowed to get dry they are liable to run to seed. At the end of June they may be watered weekly with liquid manure, the strength of which may be increased with the growth.

Turnips.

The first batch of Turnips sown in the open will be ready early in the month, especially where water can be freely had. A sowing can be made this month, but this must only be undertaken in very friable land and where the seed-bed can be watered twice or thrice daily. The "Fly" is very troublesome at this time of the year, and sometimes the sowing will have to be repeated three or four times to obtain good results.

Tomatoes.

All the plants will be well established and will require sticking early in June. The Tomatoes must be tied to the stick as soon as this operation can be done. When the plants are 6in. high they must be sprayed with Bordeaux Mixture or Strawsonite as a preventive of the diseases so prevalent in this crop. The side-shoots will want to be removed as soon as they appear, as they are detrimental to the growth of the trusses of blooms. The ground should be kept clean by frequent hoeings to induce by every means the health and growth of the Tomatoes.

Beans.

The glass should be removed from the Beans early in June and the plants should receive a good hoeing. In favourable weather some Beans will be ready for picking late this month.

Chicory.

Chicory will now be well up and the ground must be kept damp and hoed when needed. The plants should be thinned out and some thinnings may be pricked off where bare patches are showing. If they are growing too freely the bottom leaves may be removed by hand.

Strawberries.

Plants grown for runners will require hoeing and tidying whenever necessary. The bed must be kept damp, to induce a good growth in the young runners, which must be fixed firmly in the ground. Some growers plunge in the bed "sixty" pots filled with good sandy soil where the runners are placed. This system, though very slow, will be well repaid, as the plants do not receive a check when potted in July. The potting soil must be prepared if this has not been done already. The specialists around Paris prepare the soil as follows: A layer of well broken sandy loam, a layer of decayed manure, and so on. The heap is turned over every three or four weeks and watered with liquid manure.

General Work.

Watering will be the chief occupation this month. Where the irrigation has been well laid, this work will be an easy matter, and the grower will reap the benefit of his forethought by obtaining his crops earlier and will be able to set plants or sow seeds whenever his ground is unoccupied. The hose should be chiefly employed in the open, but this must be very pliable, to allow the workman to move it whenever necessary without spoiling the beds. The copper reel should

Intensive Culture of Vegetables.

be fixed at the corner of the bed to prevent the hose from cutting the crops. The rose must be very fine, having about 500 holes with a diameter of 3in.

Melons should always be watered with the cans so as the better to distribute the water; they must, too, be watered before 8 a.m., before the sun gets too hot.

Endives and Lettuces must be watered either early or very late, as when the water lies on the leaves these are liable to get spotted under the action of the sun. When cloches are used for Melons they must be shaded with limewash on the outside.

When an increase of material to be used in the garden is contemplated, the orders, especially in the case of bell-glasses, must be sent in this month, to avoid the delay which occurs very often later in the season.

When another plot of ground is to be added to the French garden this ought to be cleared late this month, especially if the land is of a heavy nature. This can be ploughed and harrowed at least twice before the following October. When a grass land is to be broken up this ought to be done early after the hay-making, and the ground must receive a layer of gas-lime—four tons to the acre—or Vaporite—2 cwt. per acre—to destroy any of the pests that may be prevalent. When the ground has been well worked, it can be laid out with pipes and well manured to be ready for use by Christmas.

JULY.

Lettuces.

As soon as the Cauliflowers are marketed from the manure-beds these should be forked down. Then two

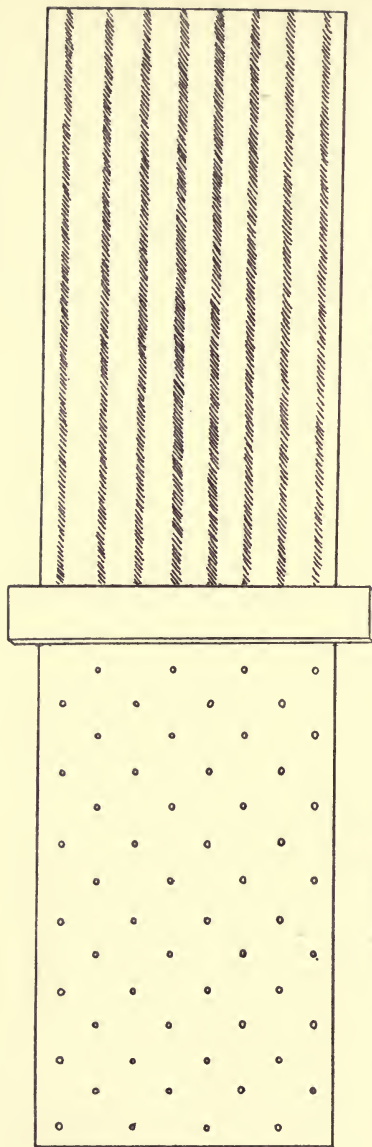

After Planting.

Drilled before Planting.

Fig. 18. Method of Planting a Bed in the Open Ground; the Workman stands upon a Plank placed across the Bed.

beds should be made into one by doing away with each alternate path, which becomes part of the bed. This path being removed, the soil therefrom should be spread on each side and dug in. The old path should be made level with the bed by bringing fresh soil from the sides. This must be done with great care, as the old trodden manure is unsuitable for the future crops.

The ground should be levelled with a rake and heavily watered before planting. To mark the rows it is a good plan to place a line on the outside row and tread it. One foot remains against the line and the other foot makes the second drill. The third row is marked by keeping the foot in the second row, turning round to make the third row in the same manner, the second row being used as a guide. This method brings the rows exactly parallel and the line can be discarded (Fig. 18).

The Cos and Cabbage Lettuces are planted as follows: One of the outside rows is set first to the exact distance. Then a board 12ft. long is placed horizontally on edge by the row, one end being even with a plant of the outside row. One plant is then set against the board on the 3rd, 5th, 7th, 9th and 11th row. The board is then turned over against the second plant of the outside row. The odd rows are set as already explained, and the even rows, the 2nd, 4th, 6th, 8th, 10th, 12th, are set diagonally with the odd rows, at a distance of 9in. for the Cos Lettuces from the board, or set with Cabbage Lettuces if they are to be grown concurrently with the former as an intercrop.

The plants when all set are well watered in and the bed must on no account get dry. A batch of seeds of Cos Lettuce Winter Red or Hardy White may be sown early in the month, to be planted late in the

Intensive Culture of Vegetables.

month for cropping at the end of September. Cabbage Lettuce Perichonne or White Passion may also be inserted at the same period for marketing at the end of August or during September. These crops must only be grown when plenty of water can be obtained and where the ground is of a heavy nature.

Endives.

Endives sown early last month for planting on the old manure-beds should be set in the same way as explained for the Cos Lettuces. It must be borne in mind that the old manure is very dry at this time of the year after the Cauliflowers, and heavy waterings must be given till the soil is in good condition for planting. The main batch for the winter crop should be sown about the 10th or 12th of July, and earlier in the month in the northern districts in the open. The varieties for this crop are La Ruffec and La Meaux. Endive Batavian Green should be sown at the same time. These crops are to be planted in the open ground. They would grow too soft in the old manure-beds, and these will be required before the Endives are ready for market.

Carrots.

Carrots sown during spring in the open will be ready early this month. Many growers sow Carrots behind the Cauliflowers grown on the old manure-beds of the cloches. These beds are prepared as already explained for the Lettuces. The germination of the seeds must be hastened by frequent waterings if good results are to be expected, and to clear the ground in time early in October. The best variety for this purpose is La Bellot, a cross between the Early Parisian

and the Nantaise. It is not advisable to sow the Carrots where a batch has been sown on the hotbeds in January.

Cauliflowers.

The Cauliflowers planted in the early spring should now be ready; but experience and judgment are required in their marketing. When pulled out too early they soon wither, and when left in the ground too long the inflorescence bursts and gets bitter. After a heavy rain or a storm a great number of Cauliflowers will be ready within the course of a few hours and would soon get spoiled if not pulled in time. A fully grown Cauliflower will keep fresh two or three days after pulling if it is stored in a cool and dark cellar.

The batch of Cauliflower planted after the first batch of Cos Lettuces in the cloches at the end of April will require heavy watering early in July till they are ready some time this month. The Cauliflowers from the seed sown in May can now be planted out among the Melons, four per light. We never advocate planting Cauliflowers among the Melons before these have been at least ten to eleven weeks in the frames, as one crop would be injurious to the other. The Melons require less ventilation than the Cauliflowers, and their growth must be on the decline before the latter are set. The last Cauliflowers are set not later than the end of July.

Melons.

Early this month the first batch of Melons will be in full bearing, to be followed very shortly by the main lot planted at the beginning of May. The watering

must be continued with the same punctuality—one can of water of 3galls. daily—all the plants to be watered before 8 a.m. The wood will not grow much when the fruits are swelling, but it may be necessary, especially in heavy soil, to remove the extra growth and also the dead leaves. When the weather is very favourable the lights may be removed altogether from the 10th of the month, exception being made in the case of the plants last set out. In small gardens the lights may be left close at hand to be replaced should the weather get cool or stormy. Round Paris they are usually packed in the shed for the remainder of the season.

Cardoons.

These plants will be growing freely, and they must on no account be kept short of water or they may run to seed. Liquid manure may be given weekly, increasing the dose with the growth.

Celery.

Celery should be planted in its final quarters as soon as the ground is available for the purpose on the old manure-beds, which should be prepared as explained for the Lettuces. They should be planted 18in. apart each way. The plants will not flag if the roots are dipped in water previous to the planting and afterwards well watered in. As an intercrop either Cabbage Lettuce, Spinach, or Radish should be chosen. Celery will not require much watering in July before it gets well established or it would soon decay round the collar. This crop is not very often grown in new gardens as it is a gross feeder and takes all the goodness out of the decayed manure, which in a new place is always limited.

Turnips.

Where ground is at liberty and plenty of water is obtainable a sowing of Turnips may be made this month. White or Rose Turnip, the Hammer Strain, or the Turnip of Croissy are varieties which can be recommended. The seeds should be sown broadcast and the beds kept constantly damp by two or three waterings daily till the first leaves are well developed. The first stage of growth of the Turnip is always the most trying for the grower at this time of the year. This crop is very successful in fine, damp, sandy soil. In clay ground the Turnip gets very strong and is not much valued by the consumers.

Tomatoes.

This crop will be at its best this month, and will claim all the spare time of the gardener in removing the laterals, tying the stems, and spraying the plants at least once with Strawsonite. When the first truss of fruit is well set a dressing of sulphate of ammonia—1oz. for every square yard—will be beneficial, followed by a good watering. It is preferable to use a small quantity of this manure and repeat the dose fortnightly. In heavy ground this crop does not require much watering, but we recommend not letting the ground get too dry, as the plants would remain inactive too long and the skin of the fruits would get hard, with liability to crack later on when the growth would restart.

From the 20th to the 25th of the month the Tomato plants should be "stopped" at one leaf over the last truss of blooms. Though the date seems to be very early for this operation, it leaves just sufficient time for the last truss to set and the fruits to mature

before the cold nights of the last fortnight of September.

Strawberries.

From the 14th of the month the grower starts his work for the next season. The soil previously prepared should be well turned over and broken up and passed through a $\frac{1}{2}$ in. screen. The plants after the bed has been watered thoroughly should be lifted and potted in "forty-eights." They should be set in frames, pot to pot, and mats may be spread over for a few days for the plants to get well established. The soil must on no account get dry, and the foliage should be damped over at least once a day.

Another bed should be prepared, well manured and dug, to receive the Strawberries in the open to supply runners for a future crop for forcing. The plants should be set in two rows in a bed 4ft. 6in. wide, leaving an interval of 2ft. 6in. between the rows in the centre of the bed. The plants should be set 18in. in the row. This operation should be done after all the plants have been potted, using for the purpose the runners left in the bed.

Chicory.

This crop will require watering and the bed to be kept clean when needed. A dressing of nitrate of soda—1oz. for two square yards—will be beneficial to the crop and assist the growth of the roots.

General Work.

The programme of the gardener this month is always a very full one. Watering will take but half labour where the irrigation has been well installed;

but where the water is obtained with difficulty the workmen are kept watering practically all day, or failure will follow. The digging of the old manure-beds and their replanting will be the chief item in the first fortnight. The Melons will also entail a good deal of work. Many fruits will be ready this month and will require inspection at least once and sometimes twice or thrice a day. The watering of the Melons will take at least two hours every morning, and must on no account be neglected. The Cauliflowers will also be ready in quantity in July. They must be looked over at least daily, and in the morning preferably. A quantity of empties must be at hand, as often after a storm in July the Cauliflowers will be ready for market within twenty-four hours. In the last fortnight the gardener must think and decide where to grow his crops the following year, to allow him to do his sowings and prickings off in places which would leave his ground for his spring crops at liberty early in October. The contract for manure for hotbeds the following January must also be sent in, so as to have the first lot coming late in August and in September while the roads are hard and dry.

CHAPTER VII.

Melon Cultivation.

Importance of the Crop.

THE culture of the Melon is the pride of the French grower. All his time, his experience, and energy are devoted thereto from the day the seeds have been inserted until the last of the fruit has been gathered. Melon culture forms the backbone of the summer work, and when preparing his programme for the year the maraîcher is ever thoughtful of the date when he will require the glass therefor.

Varieties.

The varieties grown under this system of cultivation are :

THE CANTALOUPE, OR ROCK MELON. This type is very hardy, and produces fruits heavier and bigger than the netted Melon class. The skin is often rough, and the ribs are more or less marked, according to the variety. The flesh is juicy and sweet, slightly stringy, and very thick, especially in the Parisian Cantaloupe Melon. Every gardener has a strain of his own, which he constantly improves by judicious selection, according to the nature of his ground. The Parisian and Prescott Cantaloupe Melon are those mostly grown for market. The latest fancy has been to have fruit as smooth as possible and very heavy, the average being 5lb. to 6lb.

THE EARLY BLACK ROCK MELON is a great favourite on account of its earliness. The skin is smooth and of a very dark green colour. The flesh is very thick, sweet, and well flavoured. It weighs 2lb. to 4lb.

THE PRESCOTT small early frame Melon is much cultivated round Paris. Its growth is moderate and the fruit not extra large, weighing from 3lb. to 5lb. The quality of the flesh is excellent and very juicy. It is one of the best for this system of culture.

Most of the growers choose one variety only, to avoid any possibility of a cross between the sorts, which is so likely to occur in this family.

From the time of the insertion of the seeds to the time the plants are in their final quarters six weeks are allowed, and from ten to twelve weeks elapse before the fruits are ready, according to the time of year, after they have been set.

Cultivation Summarised.

The cultivation of the Melon may be summarised thus:—

- 1st : The sowing.
- 2nd : The first potting.
- 3rd : The first pruning.
- 4th : The final planting.
- 5th : The second pruning.
- 6th : The third pruning.
- 7th : The fourth pruning.
- 8th : The choice of the fruit.
- 9th : General care.
- 10th : The picking and packing of the fruit.

Sowing the Seed.

Only good-sized and plump seeds should be used, and preferably those two or three years old, as the

wood is not of such a luxuriant growth and tends to produce more female flowers. In England the best way to insert Melon seeds is to place them in. apart in clean and loamy soil in a shallow tray. The seeds should be set in a glasshouse where the temperature is not lower than 60deg. to 65deg. F. for a quick and even germination. Where there is no accommodation in a greenhouse, a hotbed to hold a frame of one light should be made of three parts of fresh manure and one part of dry manure. The height of the bed would vary from 1ft. 6in. to 2ft., according to the time of year. When the fermentation has begun the seeds should be inserted, as elsewhere directed, and set in the middle of the frame. Some manure should be brought round the frame level with the light to maintain the temperature and to afford shelter from the wind.

It is absolutely necessary that the bed should be made in the best and most sheltered spot in the garden, as the brisk changes of temperature are very prejudicial to the tender growth of the Melons, especially from February till the end of March.

When the seeds have been inserted in a frame, mats should be placed on the light and round the bed. A constant watch should be kept on the thermometer to see that the temperature does not fall below 65deg. F. If it should, then it would be necessary to add fresh manure round the frame.

The germination of the seed, either in a greenhouse or on the hotbed, takes five or six days. Moderate ventilation should be afforded in the middle of the day for half an hour or so, according to the weather. The early sowings will never require any watering till the first potting. if the soil was in proper condition when

the seeds were inserted; but the last sowings must receive the necessary moisture for the good growth of the young seedlings.

Potting.

A heap of soil formed of three parts of good loamy soil and one part of decayed manure sifted through a $\frac{1}{4}$ in. sieve should be kept in store in a dry place for the potting of the Melon whenever necessary. When the cotyledons (seed leaves) are spread out it is time to make a hotbed to hold one frame of three lights, as previously explained for the sowing, so as to have the new bed at a proper temperature of 65deg. Fahr., plunging in the young plants a week afterwards. The lining round the frames is generally done after the setting of the plants in the frame. The young Melon plants are potted when the fermentation of the new bed has begun. This operation is always undertaken on a bright day, except when they are grown in a greenhouse, where they are potted on the spot. The plants are set in "sixty" pots (3in. diameter), the soil is not pressed too firmly, and the pot is filled to the rim. The plants are set pot to pot in the frame. The lining is done immediately, and the lights are kept closed for five or six days.

Should the weather be favourable, moderate ventilation can be given for an hour every day after the plants are well established. A light spraying of tepid water may also be necessary; but it is only done when absolutely needed for the first and the second batch of plants, sown from the middle of February. Those sown in March will require more attention as regards watering; and here a great difficulty arises for English gardeners. In the low space between the plants and

the lights, the sun dries the soil rather quickly, and at the same time the wind may prevent the grower from attending to these operations, as it would be risky to open the light for even a short time. We therefore advise rearing all the Melon plants till the

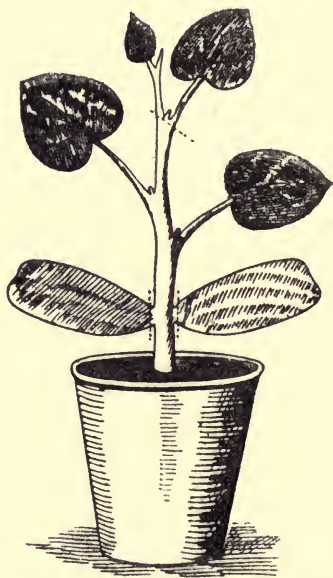

Fig. 19. Melon Plant—First Pruning.

first pruning in a greenhouse, where all the different details can receive proper attention.

When the plants require more room the pots are spread out. The good grower generally prepares a similar hotbed to the first, and transfers the plants to the new bed to give them the necessary room. This detail of cultivation entails more labour, but the manure from the first bed can be utilised over again

for other beds if needed. The plants being set on a new bed grow more evenly, and also give later on earlier and bigger fruit.

The Melons will now require more ventilation, and are ready for the

First Pruning.

This operation takes place when the plants have grown three leaves, exclusive of the cotyledons. The Melon plant is cut back to the second leaf, and the cotyledons are cut close to the stem, care being taken also to cut the minute bud or eye growing at their base. The main stem is cut through the base of the petiole of the third leaf. At that part, as it will be noticed, the stem is thicker, and the branching of the vessels from the main stem to the petiole prevents it from splitting, a very important point, as the splitting of the main stem tends to induce the destructive disease known as Collar Rot. The plants should be kept a little drier after this operation, which is always done in the morning of a bright day.

Final Planting.

When the first pruning is done it is time to prepare the hotbeds for the final planting of the Melons. Eight days should be allowed from the first pruning till the final planting, which is about the necessary time for the fermentation of the hotbeds to begin. The place where the Melons are to be grown should have been previously dug and manured, and must be free from weeds. A standard measurement for marking the hotbeds should be made on a piece of batten of 5ft. 4in., as follows:—22in. to mark a 10in. path and 12in. of the 4ft. 6in. bed; 24in. to mark the width

of the trench; 18in. from the trench to the outside of the bed. It will be noticed that the middle of the trench is 3in. out of the centre of the bed. This is done in order to obtain the full advantage of the sun

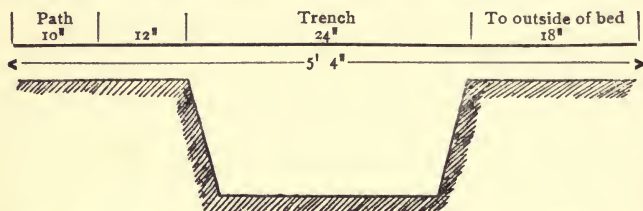

Fig. 20. Section of Melon-Beds: Open Trench for Manure.
Scale 1 : 20.

on the roots of the plants when they are in their final quarters. As all the Melon-beds are in the same portion of the garden, the first trench should be emptied out, and the soil carted away next to the place which will be occupied by the last trench.

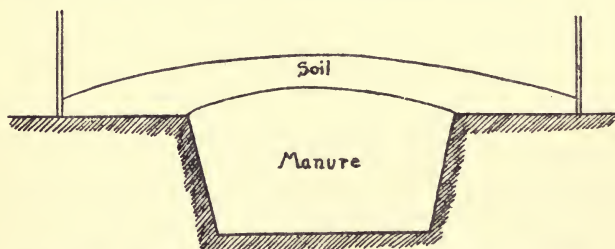

Fig. 21. Section of Melon-Beds: Bed just Completed.
Scale 1 : 20.

For the first Melons (at the end of March) the trench should be 1ft. deep, but as the weather gets warmer and the work proceeds the trenches should be made shallower—8in. for the last beds made in May.

When the trench is dug out the manure should be

brought in; when it is carted with the basket the manure should be shot down on the outsides of the trench. Fifty to sixty basket-loads are needed for the first beds, but thirty to thirty-five will be sufficient for those made in May. To make the hotbed, the workman stands in the trench, and mixes and shakes the manure well. The centre of the bed should be 2in. to 3in. higher than the level of the ground. When the bed is made it should be watered and pressed down, while the loose manure on the ground should be carefully raked towards the centre. The frames

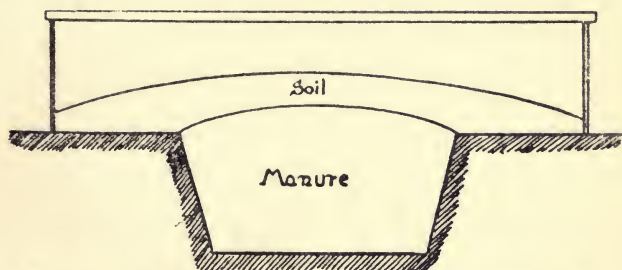

Fig. 22. Section of Melon-Beds: Ready for Planting.
Scale 1 : 20.

should next be set straight and level. They should, of course, rest on the natural ground, the manure-bed running parallel in the middle of the frames. When these have been set in their positions the next trench should be marked and dug out. The soil should be put into the frames of the first bed, care being taken to keep the centre higher than the sides. The soil should be broken as fine as possible, and two small holes made in the middle of each light. These should be filled either with well-decayed manure or with sifted soil, as later on the place will be occupied by the plants.

When a row of frames is entirely finished the lights should be set on and covered at once with the mats. When the fermentation has begun the best plants should be chosen for the planting. They should be set carefully, without disturbing the roots more than necessary, keeping the collar of the plant in. over the soil. They should be set in the centre of the second pane of the light from the top (which is the middle of the light), to avoid dripping when it rains on the most delicate part of the Melon. The main shoots should be directed one towards the top, the other towards the bottom of the lights. These should be kept closed and covered with mats for four or five days, according to the weather. The paths should be filled up with long strawy manure for the earliest batch and half-way from the middle of April. This operation should always take place immediately after the Melons are planted, in order to fill the gap under the frames and to stop the ingress of cold air, which is so injurious to the young plants.

For a week the Melons will require no special attention beyond the shading and the covering at night. When the two shoots are spreading their young stem, half a can of water may be given early in the morning, and preferably on a calm day. Later on, and especially on dry land, a whole can will be beneficial. The plants should never be watered round the collar; watering should always be done on the sides of the lights only.

When the plants are well established, moderate ventilation should be afforded and the shading dispensed with. Exception to this should be made when a scorching sun (especially after a spell of dull weather) is likely to cause the plants to wither. In

that case it will be necessary to shade for two or three hours in the middle of the day.

Air should be given sparingly at first, increasing the amount with the increase of vegetation. In April and May, care must be taken, however, to open the lights on the opposite side of the wind. In the event of a sudden change in the weather conditions the lights should be closed down till the storm is over. It is then that one appreciates to the full the handles on the top of the lights, the clips on the frames, the fact that the lights are flush with the frames, and the blocks of a uniform size, as it is often necessary to open and close 300 to 400 lights three or four times daily.

The watering necessary will increase with the growth of the plants, though it should always be moderate till late in May. The ground must be kept rather dry, so as to obtain hardy and clean wood and foliage. Previous to the full appearance of the female flowers a good watering should be given, but then it should be suspended for a week or so till the young fruits are set. As soon as these are the size of a hen's egg, and should the weather be propitious, 3galls. of water per light daily will be necessary. Hard and fast rules, however, cannot be given, especially in the changeable English climate. The grower must use his own judgment as to watering, it should be relinquished when the temperature gets lower than the average and in dull and rainy weather, and commenced again with the bright sunshine.

The plants, especially in light land, must be always kept in active growth, otherwise there is a risk of the aerial growth overtopping that of the roots. On a very hot day following dull weather the tax on the

roots is too great for them and the plants are likely to wither, sometimes with the fruits in the ripening stage. Careful ventilation and cautious watering are the only guides to success.

Second Pruning.

Twelve to fifteen days after the final planting the two stems will have developed five or six leaves. They should be shortened on the fifth leaf in the case of plants set before the first of May, and on the fourth leaf for those set after that date, as the joints will be stronger and longer. Before counting the leaves, all growth must be removed from and around the collar of the plants, leaving 3in. clear on every side. It is only after the second pruning that the Melons seem to develop rapidly. Ventilation and watering are the only things to attend to till then.

Third Pruning.

The main laterals or stems will have grown side-shoots from the base of each of the four or five leaves left on them. These side-shoots should be cut on their second leaf. Beginners often count as one leaf of the side-shoot the leaf at their base, which belongs to the main lateral. By the second leaf we mean the second leaf on the lateral.

When pruning for the third time, growers spread straw or dry manure as a mulching; this to a certain extent helps to retain the natural moisture and also forms an even and smooth surface for the resting of the fruits.

The ground should be carefully kept free from weeds, and all growth appearing round the collar must be cautiously cut clean to the stem. After this



Fig. 23. Melon Plant—Second Pruning.

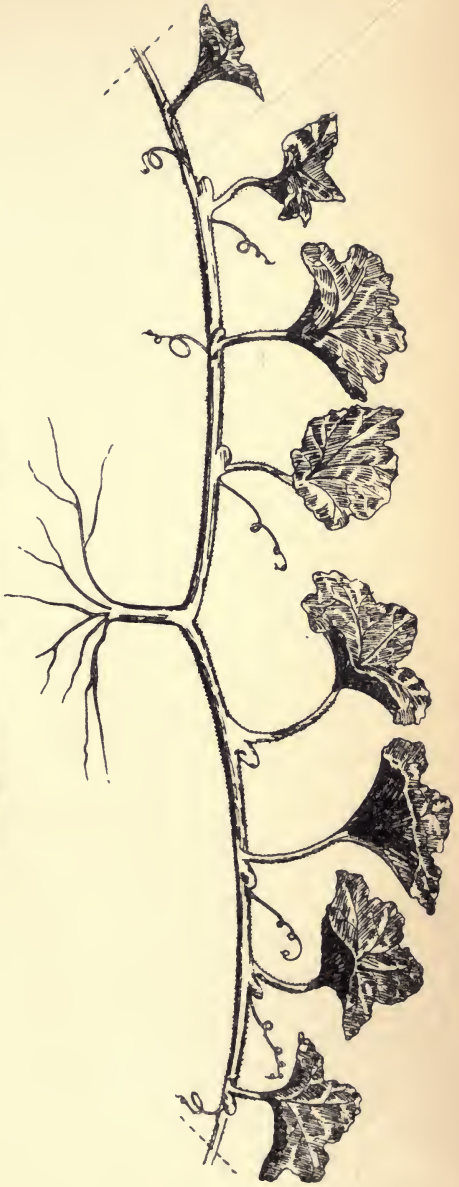

Fig. 24. Melon Plant—Third Pruning.

pruning, female flowers will appear, but these are too early, as the plants are not sufficiently strong to carry fruit.

Fourth Pruning.

After the third pruning the growth of the plants will be enormous, and for a week or ten days they must again be looked over. The buds at the base of the side-shoots will have grown young second side-shoots. These must also be stopped to the second leaf. When the leaves and wood are too thick some may be entirely removed, but only a few, so as not to check the plants. The female flowers appearing on the second side-shoots will produce the most shapely fruits.

Ventilation should be given whenever possible, as the wind and insects are the best aids to fertilisation. No artificial fertilisation is needed, as there are always too many fruits. At that period of the growth (June) the gardener will have divided his lot of Melons into batches, and will look over them every week to attend to the different prunings, and to make a selection of the fruits.

Choice of the Fruit.

As only two fruits must be left on each plant, these must be of even size and at equal distance from the start. When only one fruit is available, and when the female flowers are numerous, this fruit must be rejected till two others are grown at the proper place. If two fruits are of uneven size the bigger one will always grow to the detriment of the smaller. A perfect fruit must be oval, smooth, and even.

The plants at this stage must never lack moisture

at the roots, or the wood would get hard, when the fruit is liable to split when ripening. The growth of the wood will greatly diminish while the fruits are swelling till they reach three quarters of their full size. If the plants are healthy, the growth will then take the upper hand and the knife must again be requisitioned. The cutting will only consist of thinning out the extra wood and foliage without checking the plants. The fruits must be turned so that each part gets the advantage of the sun to prevent decay from setting in. At that period, early in July, ventilation should be left at night, and later in the month the lights may be entirely removed when the weather is warm and dry.

Picking and Packing the Fruits.

The fruit when fully grown becomes glabrous, and its dark green changes to a pale colour. A white vein appears round the base of the stalk and bursts open when the fruit is ready to be picked. This only takes a few hours, and during the hot weather it is necessary to look over the plants twice or thrice daily. When the fruits are picked they should be placed in a cold room, there to remain until they are ready for market. They should be packed in flats, or in boxes not less than 8in. deep, each fruit being wrapped in paper (care being taken not to break the stalk). The fruit being easily bruised, some wood-wool, or soft dry hay should be placed round the inside of the package and round each fruit. When packed, the fruit ripens very quickly, and it is important that the packing be done at the last hour before dispatching. A good Melon must be heavy and cracked round the stalk, which must be fresh and thick.

The bottom of the fruit should yield under the pressure of the thumb. The flavour should be very accentuated and the skin turned to a very pale yellow.

Diseases, &c.

These will be dealt with in the chapter devoted to "Vegetable and Animal Pests."



CHAPTER VIII.

Cucumber Cultivation.

General Routine Work.

CUCUMBERS, as regards the main details of culture, are treated similarly to Melons. They are not, however, so largely grown under lights during the summer, as they cannot attain in the frames the excellency of flavour and perfection of shape obtained when grown in the greenhouses; but in some localities it is necessary to grow a certain quantity as they are always in demand.

The French varieties, the White or Green Long Cucumbers, are hardier and do better in the frames than those of the Telegraph type. Unfortunately, they are not sufficiently appreciated in England to be grown on a large scale.

Seeds should not be sown earlier than the 1st April, as was explained when dealing with their allies, the Melons. The plants are potted as soon as the cotyledons are well developed, as they are liable to get drawn in a very short time: the roots should be kept moister than is the case with the Melon in the nursery bed. They should be ready for the final planting by the 10th May.

A week before transplanting is performed the cotyledons should be removed, but the main stem should not be stopped. The hotbeds should be prepared similarly to the Melon bed, but the two holes

should be made gin. from the bottom board of the frames and be filled with fine soil.

When the fermentation of the manure is well started the plants should be set in the place prepared for their reception. They should be laid on the slant, towards the top of the frame. This is done in order to avoid the curve of the stem, which in the Cucumber is very brittle. The ground should receive a good watering and the mats be kept on the lights till the plants are well established.

Ventilation should be given moderately, and should the weather be very bright the lights should be shaded with limewash, spread with a syringe. The application of the lime with a brush is not advisable, as the growth of the wood would be too soft. We prefer shading the lights with mats till the middle of June, to gain all the light possible should the weather be dull and wet.

Cucumbers require more watering than Melons, yet allowance must be made for the condition of the soil.

Pruning.

When the main stem has reached within 10in. of the top board of the frame it should be stopped to the sixth or seventh leaf. The effect of this is to force the development of the side-shoots, which should then be stopped to the first leaf. These side-shoots will bear the fruits. At the base of the leaf left a second side-shoot will grow, which will be in turn stopped to the first leaf.

Cucumbers are very prolific, and all those appearing on the main stem must be sacrificed, as they weaken the plants.

When a good strain is grown the female flowers

appear in trusses of three or four, but only one fruit is kept for every truss. The growth of Cucumbers is very rapid, and they must be looked over every three or four days, the side-shoots cut, and the young fruits thinned out. Every fruit kept must have ample room to develop straight. Overcrowding of the side-shoots must be avoided, especially when two plants are grown per light. When the plants are fruiting, air and water may be given abundantly. In July and August the lights should be placed on four bricks. These should never be taken away, as is done in the case of Melons, as the cold nights cause the tips of the young fruits to damp off. For this reason Cauliflowers are not planted in the Cucumber beds, as it would force the removal of the lights.

Except in very favourable weather only are the Cucumbers kept after the 15th September. At that time the plants would require a gentle heat at night. When they are kept the lights must be closed down at night and ventilation must be moderate in day time.

Diseases and Insects.

These are practically identical with those affecting Melons, and will be dealt with in the special chapter already referred to.—“Vegetable and Animal Pests.”

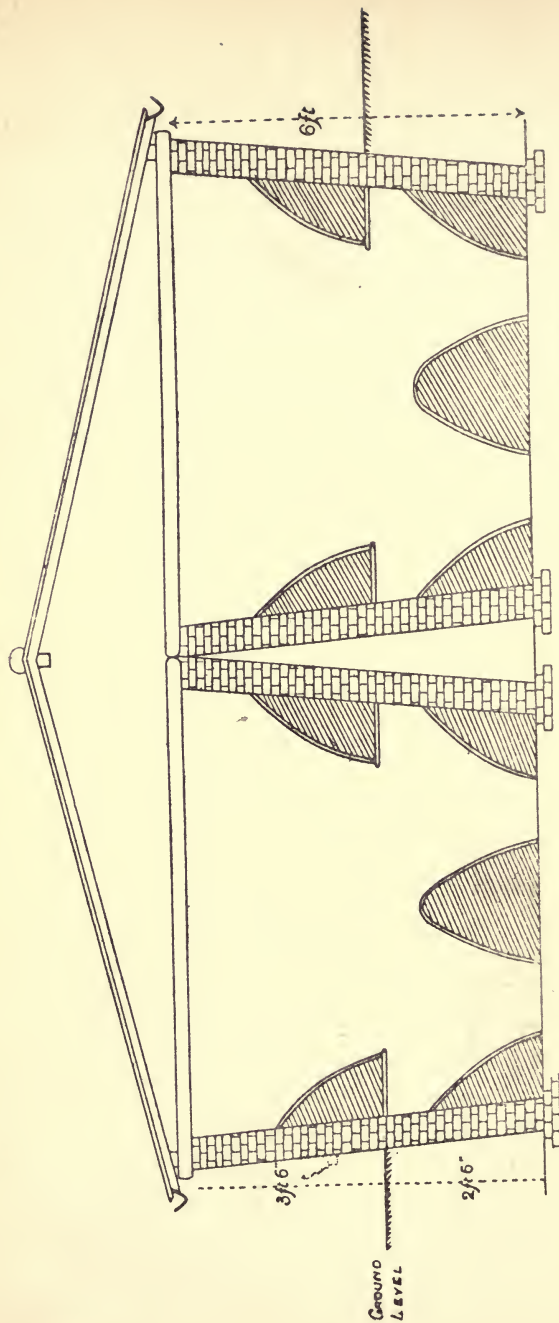

Fig. 25. Mushroom Cellars as used by Maraichers around Paris.

CHAPTER IX.

Mushrooms.

IN a French garden the common Mushroom (*Agaricus campestris*) is a supplementary crop, but a most useful one, as it is a source of income at a season which, as a rule, is very slack. Around Paris Mushroom culture is an extensive industry in itself and is generally carried on in disused quarries. The maraîchers, however, build cellars for the purpose on their own premises. They are 6ft. 6in. to 7ft. wide, and 5ft. 6in. high, and the length varies from 40ft. to 120ft. They are sunk 2ft. or 3ft. below the ground, the outside walls are of concrete, and the roof is made of old railway-sleepers laid across the two walls. The soil from the excavation is put on the sleepers, and the whole is covered with a zinc roof. Where this is done on a large scale, one roof is made to cover two houses so as to concentrate the rainfall on two gutters and thus, to a certain extent, avoid the extra dampness (Fig. 25). The main object is to provide a natural moisture without excess and an even temperature.

When building up the walls, allowance is made for a shelf half-way up the wall. By this method space is provided for three ridges on the floor and one on each shelf. An aperture is also made at the opposite side of the door so as to ensure a thorough ventilation of the place should it be necessary. Lofty and draughty places are unsuitable for Mushroom culture

where the crop is to be remunerative. Its success is dependent upon many details, but the question of environment must be an important point.

Spawn.

In reality this is the vegetative part of the fungus in contradistinction to the reproductive organs. It is known scientifically as mycelium, and lives naturally as a parasite on certain plants, such as grass, where its mycelium (so-called Spawn) mixes with the roots of the host-plants, from which it obtains starch and cellulose, and supplies in return carbonic acid gas. By this means of exchange it forces the growth of the foliage of the host, and to this cause is due the "Fairy Rings" so noticeable in pasture fields, &c. This relation between the fungus and the host-plant is called symbiosis.

Agaricus campestris has also the characteristic of living in organic matter, such as manure or leaf-refuse. Through the process of fermentation which this undergoes, it obtains the necessary nourishment for its existence. A plant so growing is known as a saprophyte. Should the mycelium of this Cryptogam be transferred from the field into the refuse its growth would still continue by reason of certain chemical influences special to its class. It is the knowledge of this characteristic which has been responsible for the development of Mushroom cultivation around Paris, where it is practised on a very extensive scale. The fungus living in symbiosis may be transferred in bricks made of manure, clay, &c., or in manure-beds specially arranged for the purpose. In this new element the mycelium, called by the grower "virgin spawn," after

having spread all over its new medium of life as a saprophyte, supplies him with "frank" spawn, which is used for growing the edible mushroom. The converting of the "virgin spawn" into "frank" spawn does not, however, end there, as by using the new spawn as a reproducer it shows whether the Mushroom resulting therefrom contains all the qualities necessary to its marketable value. Herein lies the first difficulty, as often twelve to fifteen different kinds of virgin spawn as found in the fields or on heaps of refuse are discarded as useless before a good strain is obtained. When a good variety has been found it will produce a sufficient quantity of "frank" spawn to supply a wholesale grower for from twelve to eighteen months, especially when a certain stock of the original spawn has been kept in reserve for another supply. A good strain of Mushroom is not cultivated more than five or six times, as the spawn gets weaker and weaker until eventually it is quite unproductive.

The mycelium when in the manure produces long, entangled, woolly, thread-like masses. These, called amorphous filaments, when they come into contact with another medium—as, for example, the soil covering the ridges—change their structure into long root-like membranes (rhizomorphous filaments) and produce the spore-bearer or Mushroom. Therefore, when the spawn is obtained from a ridge bearing a crop of Mushrooms, though the grower is careful during the cleansing to eject some of the rhizomorphous filaments, those that remain start growing again when the spawn is utilised for another ridge. These filaments are only useful because of their capability to produce the mushroom itself: by them-

selves they are useless as reproducers, as they have not the power to branch. When they are already present in a spawn, their number still further increases by reason of the fact that the amorphous filaments produce them, the mycelium weakens, rendering it more liable to the attacks of fungi harmful to its growth and causing its complete failure. It is absolutely essential, therefore, that only new or "frank" spawn be used as a reproducer.

Where Mushrooms are grown as market produce, the making of the spawn ought to constitute a branch of the work, to enable the grower not only to know the quality of the produce but, above all, to be certain of the health and vitality of the spawn. This system of reproduction is not the natural way of increasing the species; it is analogous to propagation by means of layering, cuttings, or grafting in the plants of a higher order. Natural propagation is by means of the spores. Of course, as long as the grower is able to get virgin spawn from the field or other medium he will not think of inserting spores. However, around Paris this method is useful in cases where genuine virgin spawn is becoming more and more difficult to obtain owing to the great demand there is for it. Moreover, even where such mycelium has been found, there is no proof that it is the produce of self-sown spores, or that it is the new growth of worn-out spawn left at the spot knowingly or accidentally by some interested party.

The great objection to the use of spawn from the field is that it does not possess sufficient vitality to fight against the numerous diseases which attack it, and when we know that one of these (*Hypomyces perniciosus* Fig. 26) causes damage to the extent of

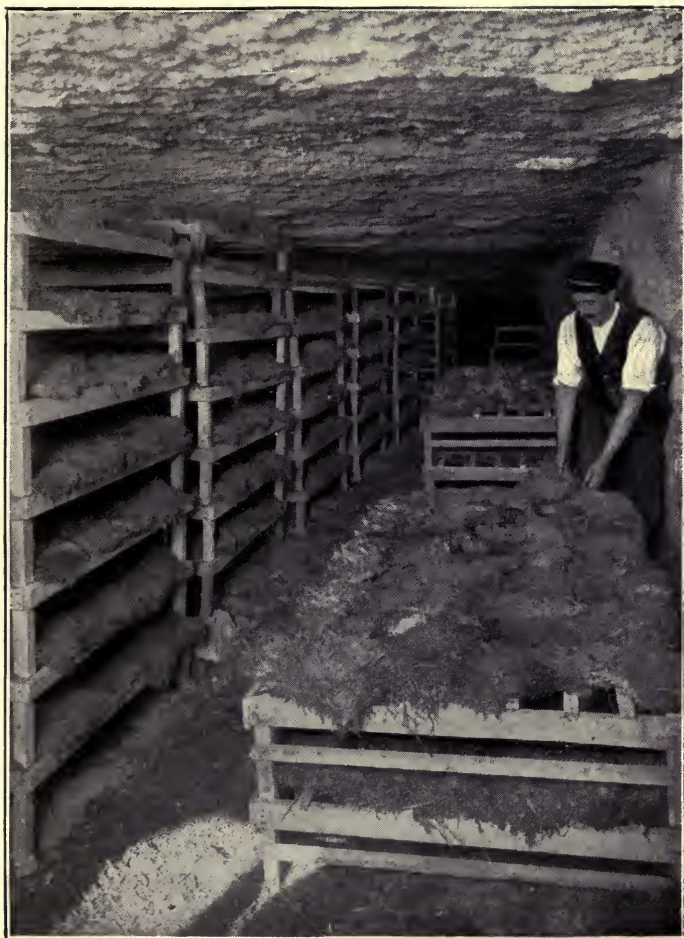

[*Illus. from P. Gêneaux, Paris.*

Mushroom Culture—Preparing and Drying the Spawn.

£40,000 per annum we can well understand the anxiety and care of the grower in the choice of his spawn.



Fig. 26. Mushroom Fungus (*Hypomyces perniciosus*).
(By permission of the Board of Agriculture and Fisheries.)

Of late years great researches have been made in order to obtain mycelium from known spore-bearers,

and the staff of the Institut Pasteur have devoted their knowledge and their time to this important question. Drs. Costantin, Matruchot, and Repin have been able to introduce into commerce some mycelium obtained through the germination and growth of spores from selected Mushrooms.

A good spore-bearer from a clean crop is collected when the hymenium, or "head," is well open; this is dipped in water that has boiled and been allowed to cool to a temperature of about 100degs. Fahr. After a few hours the spores will have spread by thousands in the water. Some medium—such as well-prepared manure—is then placed in a tube, and the water containing the spores is put over it, the tubes are hermetically sealed and placed in a bath of water kept at a constant temperature of 65degs. Fahr. In from twenty to twenty-five days the mycelium begins to appear and can be utilised for propagating purposes.

Of the transition stage between the growth of the mycelium in the tube and its acclimatisation to the ordinary cultivation little is known, except by those who have paid special attention to the science of the subject, and who deserve the thanks of the community. The sowing of the spores in the ordinary way has been practised, and with care may easily be done. The spore-bearers are chosen with great care, and the heads are kept in an upright position until they are very ripe, when the gill plates turn black. They are then immersed in water as already stated. Certain growers, however, simply place the Mushroom, head downwards, in a layer of well-prepared manure in a sufficiently damp shed, and where the temperature will not exceed 50degs. to 55degs. Fahr. After a few days the spores will have spread in the manure, which

is pressed as tightly as possible; the thickness of the layer ought then to be about 2in. By this process it takes from three to four months for the mycelium to spread all over the manure. As the locality will be also just as favourable to the growth of other spores, it will be necessary to disinfect it by spraying the wall, ground, &c., with a weak solution of copper sulphate (1 in 1000).

Without entering into any details of cultivation, we have tried to demonstrate that it is absolutely necessary to have exceptionally strong vitality in the spawn if a good crop is to be secured, because the mycelium weakens as the cultivation proceeds. It has to perpetuate the specie by forming rhizomorphous filaments, the carrier of the future spore-bearer, when it comes into contact with a medium like soil. With this increase however, there is a decrease of the amorphous filaments so necessary to the grower for propagating purposes.

When a grower has a valuable strain, and wishes to keep it, he is aware that under the influence of the atmosphere and the heat of the manure-beds the mycelium will get weaker and weaker and eventually perish. He therefore reverses the cycle of growth and forces the mycelium not only to produce amorphous filaments, but to kill the rhizomorphous filaments which produce the spore-bearer. This spawn during the winter is put into ridges of manure in the open air and well covered with straw or other material to prevent extra moisture. The mycelium under more natural conditions and in an excellent medium soon establishes itself and regains the vitality so needed for its cultivation. This is what is known as rejuvenating the spawn. By this method a good

strain will last a long time, especially when a certain reserve of "frank" spawn grown for the first time has been kept.

Gathering the Spawn.

Whichever way may have been adopted to obtain "frank" spawn—whether by cultivating the virgin spawn found in a field or on refuse, or by means of the spores, and by rejuvenating the spawn—even when it is intended to obtain a fresh supply from spawn already under cultivation, the methods are similar. In the latter case the proper time to obtain the spawn is when white marks are noticeable on the soil of the ridges. These are cut in slices (1ft. wide) after the manner of hay from a stack; when the ridges are thus cut transversely a careful examination is made to see that the mycelium has spread evenly all over the manure. The flakes of manure are then split in cakes 2in. or 3in. thick. All rhizomorphous filaments are carefully discarded, as they are easily differentiated, being thick and cylindrical, whilst the others are branched and thin. The manure also when the mycelium is ready has a smell similar to that from the Mushroom.

When little round white particles or yellowish-green filaments are observable, these indicate the presence of two diseases—*Monilia fimicola* and *Pleurotus rutilus*. Such mycelium must be discarded. When the cleansing has been done, if the spawn is not needed at once, it is carried into a special drying-room, where there are shelves made of wire-netting or of lath-wood, on which the flakes are arranged in single layers to dry. The spawn should be frequently examined and turned over, especially in damp weather, to prevent

the growth of the mycelium, which would render it unsuitable for cropping purposes.

Manure.

The medium in which the mycelium grows best as a saprophyte is horse-manure. As we have explained, it is the only way that the Mushroom can be cultivated, as when it lives as a parasite it consumes the gases ejected by the host-plant, when the production lasts as long as the life of the host. The manure must be fresh and from hard-worked horses, as it contains more ammonia, due to the high proportion of nitrogenous food given to them.

It has been proved by eminent experts that the Mushroom does not live by the absorption of soluble substances as produced by decomposition, but by the insoluble food present in the manure, and this is only found in the straw. We must not conclude that the straw could be used with success by itself, as the fermentation would be unable to perform the function necessary to the production of the cellulose and oxycellulose, which constitute the chief nourishment of the mycelium as a saprophyte. Ammonia is the active principle responsible for the fermentation. When this reaches a temperature of about 170degs. Fahr. it causes the oxidisation of the manure, which continues the chemical action of the ammoniacal fermentation, producing the cellulose and oxycellulose from the dissection of the straw. At that period the manure is at a temperature of 180degs. to 190degs. Fahr.; this destroys the numerous microbes causing decomposition, which it must be the aim of the grower to prevent. As the water—the necessary medium of the oxidisation—evaporates at such a high temperature,

it follows that this evaporation stops the chemical processes, and consequently the manure would harbour the microbes causing decomposition if it were allowed to remain as it was. This explains the necessity for turning it over and bringing towards the centre of the heap the outsides, where the fermentation is at the lowest. The shortage of water is also made good, and the chemical fermentation starts afresh to supply a bigger store of nourishment.

The proper condition of the manure for Mushroom-growing is well known to practical men. It must be free from any ammoniacal smell, of a light brown colour, and when pressed in the hands should not give out any water. It may be unsuitable from two causes having the same origin. First, lack of water when fermenting. In this case the manure is whitish and dusty. A good soaking and another turning will then be advisable. Secondly, from an excess of water. When this is due to the wet weather the manure will be unsuitable for the purpose for which it was intended. But when it has been left too long under the animal fermentation will be accelerated by a spraying of ammoniacal salts.

Preparation of the Manure.

The manure should be brought to a spot where it can be conveniently worked. In well organised places an open shed is installed for preparing the manure in during bad weather. It should be turned, well shaken, and always laid the same way. The height of the stack should vary between 3ft. and 4ft. 6in.; the width and the length will depend on the quantity required. For such a cave 40ft. long as described twenty tons will be needed. When pre-

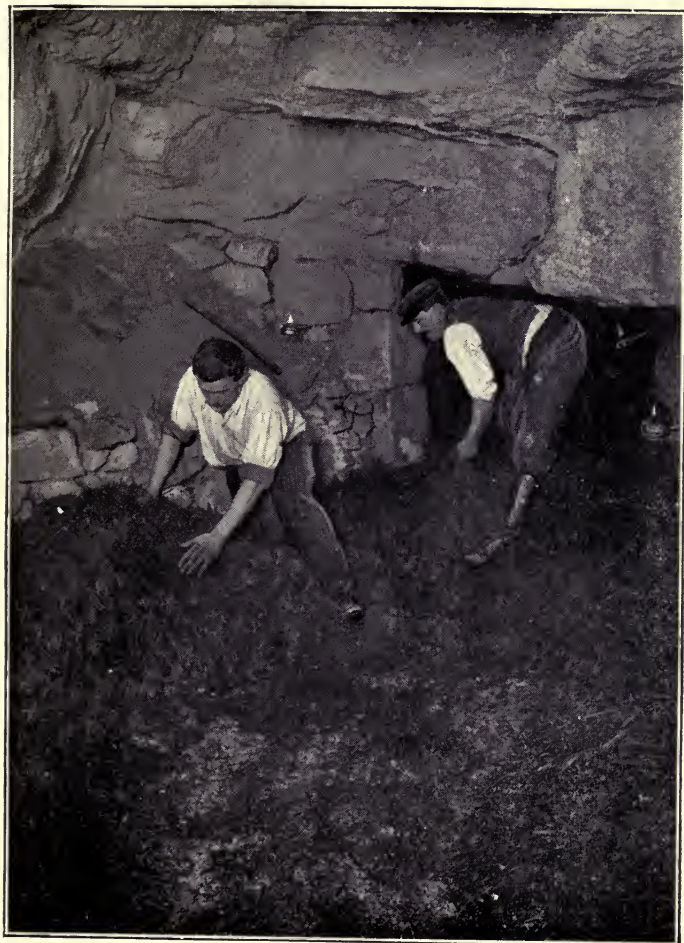

[Illus. from P. Géneaux, Paris.]

Mushroom Culture—Arranging the Manure in Heaps.

paring the manure it should receive a good watering to induce fermentation, except from November to February, when the natural dampness is often too great. After seven or eight days it should be turned a second time, starting from the side where the stack was finished. The height of the heap should be maintained by making the stack narrower. The manure should be well worked as at first, and the outsides of the stack brought into the centre, and *vice versa*, in order to obtain an even fermentation all through. If it should prove too dry in places, these should be well watered as the work proceeds, but should the reverse be the case, the stack should be made in the shape of a roof to prevent the accumulation of more moisture than is necessary. The heap of manure will be ready for ridging in from six to eight days after this second turning.

Cellar Culture.

Mushrooms may be grown outside in cellars, quarries, or frames, according to the time of the year and the material at disposal. The best time for their production is from the end of August to the end of April, when the natural moisture is especially favourable to their growth. This does not, however, apply to the quarries, as the depth at which these are made is a guarantee that sufficient moisture will be ensured even during the summer.

From August till the end of September beds may be made in frames; from September till March in cellars; and from March outside. Where possible it is preferable to grow Mushrooms in cellars from the beginning until the end of the season. The place intended for their cultivation must be scrupulously

clean, and have received ample ventilation; while a spraying of copper sulphate 1 in 1000 on the walls and ground will act as a preventive against disease. Before making the ridges the necessary quantity of manure should be brought in. These measure 15in. to 16in. at the base and 18in. in height. They are built by spreading the manure evenly and pressing it very hard with the closed fist and the knee. As the work proceeds, the sides are kept very even by pulling out all the overhanging pieces of straw. The chief point is to press the whole evenly in the centre as well as on the outsides.

Fermentation will soon start anew, and this must be carefully watched. When it is too excessive, holes should be made with a pointed stick across the ridge from place to place, or the manure be lifted so as to make a small aperture through the bed. Ridges built on shelves are made similarly to those on the ground, but with one slope only towards the centre of the cellar. The manure must be pressed very firmly against the walls, so as to prevent gaps from forming between during the growth of the spawn.

Spawning.

When the temperature of the ridges is decreasing is the correct time to insert the spawn, which should have been kept in a warm and moist shed for from six to eight days. It should be broken in small cakes, 1in. thick and about 2in. square. Two rows should be inserted, the first about 2in. from the ground, the second 4in. over the first. Each portion should be 8in. apart and set in dovetail fashion with the other row. The spawn must be set on the outside edge of the ridge and pressed firmly in position. In three or

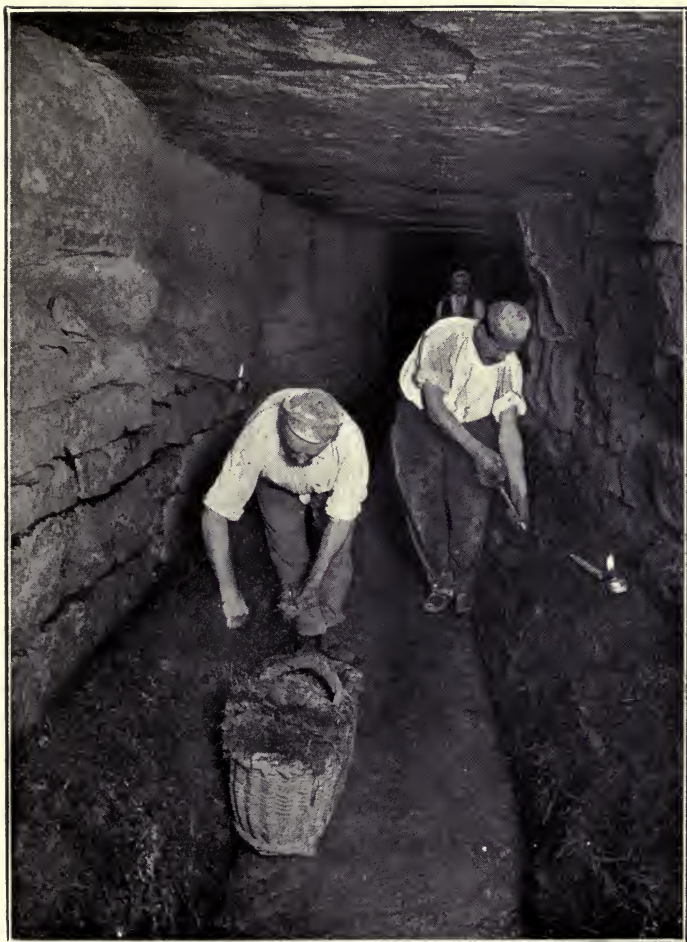

[Illus. from P. Géneaux, Paris.]

Mushroom Culture—Planting the Spawn.

four weeks, under favourable conditions, the mycelium will have spread all over the ridges. The beds should then be pressed very firmly and the surface made as even as possible with the hands. The old spawn should also be removed, care being taken not to disturb the young mycelium. When the ridges are intended for propagating purposes the only attention needed will be to keep the beds sufficiently moist to promote the healthy growth of the mycelium. However, when this work is done in the open, the ridges should be kept covered with a good layer of straw, which should be renewed as necessity requires, to prevent extra dampness. This operation is generally done during the winter, and the natural moisture of the ground will, as a rule, be sufficient for the growth of the mycelium.

Covering the Ridges.

When growing a crop of Mushrooms it is essential to place on the ridges a medium antagonistic to the growth of the mycelium, and to force it to bear Mushrooms. The medium used should be soil of heavy nature mixed with three parts of limy or chalky material—such as old plaster or refuse from stone quarries finely sifted. When the soil is of a light nature, two parts of the latter will be sufficient. The compost must be very fine, well mixed together, and made sufficiently moist. The soil should be placed evenly on the ridges about $\frac{3}{4}$ in. thick. The ridges should then be watered with a fine rose. The following day the soil should be made firm on the ridges by pressing it with the back of a shovel, and after this operation the paths should be swept clean. The only after attention that the beds will require

is to be kept moist by watering them with a fine rose. The paths should also be watered to promote a damp atmosphere favourable to the growth of the Mushroom. There is, however, no strict rule as to the watering, and the grower must use his own judgment, taking into consideration the state of the weather and outside temperature.

White marks will appear through the soil in from twenty to twenty-five days after covering the ridges; this is the first sign of the future crop. In fact many experienced growers can estimate by the growth of these whitish marks the kind of crop they may expect.

Frame Culture.

Where there is no special accommodation for cultivating Mushrooms they may easily be grown in frames and lights, which are usually at liberty from August till the early spring. A trench 14in. deep and 3ft. wide should be made and a layer of manure 6in. thick arranged at the bottom of it and pressed down firmly. The spawn should be set every 4in. or 5in. on the edges of the manure. Another layer of manure 8in. thick should cover the spawn. Holes should be made 1ft. apart through the bed to prevent too high a temperature, and the whole should be covered with soil specially prepared as previously explained. The frames and lights should be brought on the ridge and kept closed.

The bed must be sufficiently but not excessively moist. When the Mushrooms appear, mats should be put on the lights, in order to obtain white and fine heads. A constant supply may be obtained if the frost is kept out by filling the paths between the rows of frames and covering the lights with straw. Owing



[Illus. from P. Géniaux, Paris.]

Mushroom Culture—Watering the Completed Ridges.

to the depth of the trench this method of culture is only suited for light ground from which the excess moisture drains off readily.

Open-Air Culture.

Where this method is adopted, the ridges should be built in a sheltered position and on a well-drained ground. The manure must be in a drier state than that for use in the cave, and the ridges should be made bigger—2ft. wide and 2ft. high. The bed should then be covered with dry manure, or, better still, with straw. This covering must be renewed whenever necessary, so that the rain will not get to the ridge. Spawning should be done in the same manner as explained when dealing with Mushroom-growing in cellars, but in this case the spawn must be very dry. The soil should be in position when the mycelium has spread all over the manure, which will be in about thirty days after the spawning. The best time for practising this method is late in August, when the first picking may be made late in October and for three or four weeks after, according to the weather. In the early spring another crop can be gathered from the same bed, provided it be well sheltered from severe frosts.

Diseases.

The diseases to which *Agaricus campestris* is subject are caused by other fungi which, being hardier and healthier, destroy the host plant in time. *Monilia fimicola* is generally found in the manure during the fermenting stage, particularly if the straw be of poor quality or harvested before it was ripe, or again when it has been obtained from badly-fed horses. It

is easily noticeable, as white spots are formed on the manure, making it appear as if it were sprinkled with lime. A watering with copper sulphate one part *diluted* in one hundred parts of water will easily destroy it.

Pleurotus rutilolus is induced by both a damp and a cold soil and also by wet and cold manure when making the ridges. Its mycelium mixes with the filaments of the Agaric till it destroys them. As the medium of its growth is slightly different from that of the Agaric, and as it thrives in a colder atmosphere, it is absolutely necessary to use only fresh and hot manure and clean soil for the Mushroom. Where this fungus has been noticed no spawn ought to be obtained from the attacked beds for propagating purposes unless great care is taken to separate its mycelium, which is of a yellowish-green colour and emits a strong smell.

Hypomyces perniciosus (Fig. 26) is the greatest foe of the mushroom-grower, as it attacks the esculent itself. It has been very thoroughly described in Leaflet No. 139 issued by the Board of Agriculture and Fisheries. Its mycelium lives also with that of the Agaric, and the reproducing organs are developed on the Mushroom, causing it to be deformed, gradually to decay, and to emit a most objectionable smell.

This disease is not prevalent in new localities, and experience has proved that attacked spawn removed from an infested place to a clean cellar has grown free from the disease. The propagation is therefore due to the spores, and the manure and soil from an infested shed ought to be carried outside and sprayed with copper sulphate. Great cleanliness is strongly recom-

mended in scraping the ground where the beds stood and carting all refuse outside. A spraying of the shed with copper sulphate before starting new beds will also be most desirable. This disease will never assume the proportions in England it has reached in France, where the difficulty experienced of freeing miles of quarries from the spores of the fungus is great.

Picking.

Within twenty days after the appearance of the marks referred to on the soil (p. 164) the Mushrooms will be ready for market. The size of these varies greatly, and great care must be taken to know when one is ready for picking. When the head of the Mushroom is firm against the stem it is too soon to pick, but when it forms a hollow ring against the stem and gives way under the pressure of the finger it is ready. The stem is held between the first two fingers and twisted lightly round till it comes away. Sometimes the Mushrooms appear in a group; in this case the young ones left must not be disturbed when picking the others. The Mushrooms are put directly into the basket. When taken into the shed the bottom part of the stem is cut off, as it is often soiled. A great advantage of the culture of Mushrooms in caves is that they require no covering and always produce clean and white heads. The Mushrooms should be sorted into three or four sizes for market and packed in chip baskets containing 4lb. to 6lb. When in full production the beds must be examined daily, and in hot weather twice every day. If the Mushrooms cannot be dispatched at once they should be left in the cellar, as they will keep in better condition there than in a shed.

CHAPTER X.

Seed-Saving.

A CAREFUL perusal of the preceding chapters will probably have convinced the prospective French gardener of the importance attaching to the quality of the seeds and the choice of the true strains. The plants resulting from them have only a limited period in which to develop and have to obtain from a very rich medium the necessary nutrition for their growth. For this reason only a comparatively few varieties can thrive under such conditions. Several varieties of each vegetable have been mentioned in this work as having proved themselves reliable in the majority of cases; there are, however, others that may be grown with equally good results.

Lettuces, Turnips, Carrots, Celery, and Radishes have, however, been grown in every French garden for numbers of years, and, though new strains have been and are still being experimented with, no great improvements on existing varieties so far have been produced.

Cauliflowers, Cabbages, Melons, Cucumbers, and Onions, being more or less grown in the natural soil, the cultivator must judge from his own experience and special requirements which particular varieties are best adapted for his work. When one holds good strains, it is advisable to grow from such seeds, as it is the best and most reliable method, for they retain

the true character and may be further improved by judicious and careful selection. Only a few plants of each sort will give a sufficient supply for a year's stock. Seeds of previous years must therefore not be discarded until the new crop is harvested, so as to enable the cultivator to make up any deficiency in case his crop does not come up to expectations. The vitality of the embryo varies with each variety of seed, as will be seen from the Table herewith, taken from "Plantes Potagères," published by Vilmorin, of Paris, which has been compiled with great care and after extensive trials.

WEIGHT AND VITALITY OF SEEDS.

	Number of seeds in 1 gramme.	Vitality.	
		Average.	Maximum.
		Years.	Years.
*Carrot, cleaned	950	4 or 5	10
" uncleaned... ..	700	4 or 5	10
*Celery	2,500	8	10
*Chicory)	600	10	10
Endive)			
Cabbage	300	5	10
Cauliflower	550	5	10
*Cucumber	35	10	10
Lettuce	800	5	9
*Melon	35	5	10
Onion	250	2	7
*Radish	120	5	10
Spinach (Round Seeds)... ..	110	5	7
" (Prickly Seeds)	90	5	7
*Turnip	450	5	10

* Where an asterisk has been placed to a vegetable it signifies that the seeds, after the period indicated, had not lost their vitality entirely.

In order successfully to grow plants for seed, one needs to know the type, character, and affinity of each

strain; whether the plant is an annual, as Radish, Turnip, Spinach, Melon, &c., or a biennial, like Celery, Carrots, and Onions. Cabbages are treated as biennials, while Cauliflowers are grown for seed as annuals. It is also important to know whether the plants are hermaphrodite, *e.g.*, Lettuces, Radishes, Carrots, Celery, Cauliflowers, &c.; monœcious, as Melons, Cucumbers, and Marrows; or dioecious, as Spinach.

Plants belonging to the same family must not be grown concurrently, except when a sufficient distance is allowed between the seed-bearers and when the period of flowering is at different times. Colleagues often mutually arrange to grow varieties belonging to the same family and exchange seeds at harvest-time. The *Cucurbitacæ*—Melons, Cucumbers, Marrows, and Pumpkins—are very apt to cross-fertilise, owing to the long period over which each plant bears male flowers; and it is necessary to discard the crop of one when seeds are wanted from another.

The selection of seed-bearers is relatively an easy task where thousands of the same variety are grown together, and when either earliest or latest plants ready can be chosen according to the improvements required. From old-established gardens beginners can obtain a stock of the true strains, whether in the shape of seeds or plants. All seed-bearers should be grown in the natural soil and not in the decayed manure, which is an objectionable medium for the purpose, as it tends to promote a luxuriant growth of foliage to the detriment of the organs of reproduction.

The following directions are only applicable where a small quantity of seed is required for one's own purpose and where special care and attention can be given.

Hermaphrodite Annuals.

Radishes.—Seed-bearers are chosen from the earlier batches sown in the open ground, part of a bed being left for the purpose. When the roots have attained the size of a walnut the best specimens are sorted out; they must be of even shape, smooth skin, very definite as to colour, and not too luxuriant as to foliage. They should be lifted and planted out 18in. apart, in well prepared beds, receiving ample moisture, especially after the setting of the flowers. The flower-stems should be tied to a strong stake. When the pods are swelling, care should be taken to shelter them from the attacks of the birds.

Turnips.—Plants should be obtained from the batch sown in the middle or end of April, which has been grown luxuriantly and without check. They should be selected from the earliest ready. The roots must be smooth and of a bright colour. The tapering roots should be very thin from tip to end, whether the variety is round, long, or of hammer shape. They should be set 18in. to 20in. apart in a good bed, and should receive similar attention to that advised for Radishes.

Lettuces.—For the Cabbage Lettuces Passion, Little Gott, Black or White, seeds should be chosen from plants grown in the cold work. Such plants must be of vigorous growth, with the bottom leaves well expanded and the head flat and firm. They may be left in their place or lifted carefully with a good ball of soil to the roots and set 18in. apart in a frame specially prepared for the purpose. They may even be planted in the open ground at 2ft. apart. When well established, an incision in the form of a cross should be made on the head of the plant, with a sharp

knife, so as to facilitate the expansion, outwards, of the flower-stem, which should be securely staked. The young flowers must be sheltered from the wet weather by covering the inflorescence with a bell-glass or by placing the lights on the frames. The seeds ripen gradually, and should be hand-picked till the bulk is ready, when the stalk should be cut, wrapped in paper, and placed, head downwards, in a shed to dry. The first seeds picked are generally the best. Cos Lettuces should be chosen from plants planted outside in March. They should be left in their place and grown similarly to the Cabbage Lettuces.

Endive.—Seed-bearers should be taken from the first batch planted outside. They must have been grown well, and without check from the sowings. The biggest specimens should be selected and they should not be bleached like those intended for market. Generally they are left in their quarters to develop the flower-stem. Growth must be kept active by frequent waterings, so as to be able to gather the seeds as early as possible. These should be picked when ready, as they easily separate from the perianth. The Batavian Green is grown similarly, except that the seed-bearers are chosen from those sown in July. They should be sheltered with bell-glasses and mats during the winter when necessary.

Cauliflowers.—For seed-bearers, the earliest and biggest inflorescence from dwarf and sturdy plants should be chosen from the batch planted outside late in March. When the flower-stems break away from the head those remaining should be cut with a knife, as they hinder the expansion of the others. Early in July the stems should be sprayed, at night for choice, with a con-

coction of soft soap (2oz.) diluted in 3gall. of water, to destroy greenfly. Lights should be fixed on strong posts to cover the flowers and shelter them from rainy weather and to facilitate shading should the weather be too bright, both being detrimental to the growth of the organs of reproduction. It is the most critical period in the lives of the plants, and special care should be taken to safeguard the crop. On no account must the plants be allowed to get dry at the roots; and growth should be stimulated with liquid manure at regular intervals. The seeds ripen late in September, and the stems should be hung in a shed for from six to eight weeks before being threshed out.

Monœcious Annuals.

Melons.—Fruits selected for seed purposes should be chosen from good healthy plants set out at the end of April or early in May, preference being given to those carrying one fruit on a plant. It must be very heavy, as oval as possible, with a smooth skin and ribs hardly marked. It should be picked when fully ripe and the seeds taken out, placed in a very fine sieve, and washed under a tap. When they are cleaned, they should be put in a basin of water and all those which float should be rejected as useless. The remainder should be dried in the sun before being packed away. When growing Melons, better results are obtained from seeds that are two or three years old. Plants from young seeds are too luxuriant in foliage and tend to produce a bigger average of male flowers.

Cucumbers.—When smooth, long, and regular fruits are seen swelling at the base they should be left on the plants and all young ones carefully thinned out. When they assume a yellowish tint they should be

picked and placed in a shed fully exposed to the sun, till they get mellow. The seeds should then be extracted and prepared as explained for the Melons. The number of fertile seeds is usually very small, and it is advisable to select several fruits as seed-bearers.

Dicœcious Annuals.

Spinach.—This is one of the few dicœcious vegetables grown. A full bed from the autumn sowing should be left for seeds, allowing ample room around each plant. The bed should be kept clean and moist to ensure a healthy and good growth. The male plants when dying off should be pulled out, so as to leave more space for the seed-bearers. When those are ripe they should be placed in a frame in which some paper has been previously spread out. The lights should then be put on and left till the plants are dried up, when the seeds will shell out easily.

Hermaphrodite Biennials.

Celery.—A row of a good strain should be especially planted out 2ft. apart late in June or in July, in a heavily manured ground. They should be treated similarly to those grown for market, with the difference that they are neither bleached nor earthed up. They should be sheltered from heavy frosts by covering them with bell-glasses or dry straw. Early in the spring they should be cleansed of all decayed leaves and growth should be stimulated by some good fertiliser, such as guano. The ground should be stirred with the hoe, and when the flower-stem appears it should be securely fastened to a stake. As Celery is very prolific, the smaller umbels should be thinned

out before the flowering period. The seeds are very minute and great care should be taken when collecting them. The umbels should be cut and placed in a bag to be threshed.

Carrots.—The roots chosen for seed-bearing should be very smooth, clean, and of a bright red. The collar of the leaves should be very small. Several roots should be cut to make sure that there are no woody parts in the pith. The roots preferably should be obtained from the sowings made in July, and placed late in November in sand, the collar being exposed to the air. Precaution should be taken to shelter them from frost by spreading straw or hay over them. Early in March they should be set out 2ft. apart and receive similar attention to that advised in the case of the Celery.

Cabbages.—Plants intended for seed purposes should be studied and watched during the last stage of growth. They should be marked off and left in their quarters for a month or so after the others have been marketed. The head should then be cut off, not too low down the stem, and the rooted stumps set in drills 6in. apart, where young shoots will soon appear round the cut. During winter these stumps should be split lengthways, each part yielding side-shoots and a proportion of the roots. They should be planted in good ground 18in. apart. The side-shoots yield the flower-stem, which appears early in the spring, and it must be sheltered from heavy rain. Seeds ripen early in August and should be spread out in a frame to complete the drying process.

Onions.—Seeds of this excellent vegetable are easily produced. Bulbs intended for the purpose should be chosen when growing. They should be flat or

globose, according to the variety. The neck should be very thin and well accentuated. They should be lifted and dried in the usual way. In October a trench should be dug out about 9in. deep, some well-decayed manure placed at the bottom, about 3in. thick, and the soil returned. The bulbs should then be set 2in. deep and 9in. to 10in apart. In the early spring the flower-stems will appear, and some strong string should be placed on each side of the row and fixed at regular intervals on good stakes. If tied as other plants, the ties would cut the stem, which is very brittle. No special care is needed with the exception of the necessary waterings during growth. The heads should be cut when the shells containing the seeds begin to split, and should be left to dry in a bag in a shed.

Chicory.—When lifting the roots in November for bleaching, a few dozens of long, thick, and smooth ones should be sorted out and planted immediately in rows 2ft. apart each way. They may be covered during the winter with straw, but only in case of severe frost, as it would produce a premature growth of the foliage. They soon start into growth in the early spring and must be securely fastened, as the head is very large when fully developed. The ripening of the seeds should be carefully watched, and they should be gathered as soon as ready to prevent unnecessary waste.

CHAPTER XI.

Vegetable and Animal Pests.

ONE of the great advantages of French gardening is that practically all the produce grown is obtained from seed—a natural system of increase responsible for a greater vitality and quicker growth than that obtained from plants produced from cuttings, layers, or grafts. The principle of even and constant growth helps to keep plants healthy and practically immune from disease. Unfortunately, however, some diseases appear at certain times of the year, and the grower must be prepared for them.

Lettuce Mildew.

The greatest enemy of the French gardener is Lettuce Mildew (*Peronospora ganglioniformis*). This fungus appears on the young Cabbage or Cos Lettuce. The disease puts in an appearance towards the end of November and quickly spreads over all the young plants, causing their leaves to shrivel or even the whole plants to perish. When Lettuces even slightly attacked are set on the hotbeds the fungus finds in the moderate temperature prevailing just the conditions suited to its growth and often destroys the crop entirely. It has, however, been noticed in the case of plants grown by the cold system or in the open that they gain the upper hand in their quarters, and when they have once recovered from the check they sustain they develop into clean and sturdy specimens.

For many years this disease has been very prevalent in France and it is estimated that the damage caused by it amounts to £40,000 per annum. Monsieur Maxime Cornu, late Curator of the Jardin des Plantes, Paris, has studied very carefully the life of this fungus, and presented in 1892 a report to the Academie des Sciences. He said that this *Peronospora* has many points in common with *Peronospora viticola*, which attacks the vine, and he believed that it could be destroyed by spraying with a solution of copper sulphate. A few years ago M. Curé, one of the masters of this system of culture, conducted some interesting experiments, and perhaps with the help of science and continued experiments of such an expert we may still find a remedy. The solution he used was as follows: Copper sulphate, 1000 grammes; ammonia, 1250 grammes; water, 25 galls.

The result was that the new growth was clean and healthy, and after removing the dead leaves the plants grew to a marketable size. The drawback was the severe check which the plants received, ending in their not being of a first class quality.

M. Curé strongly advocated that the disease ought to be prevented by employing some other fungicide than copper sulphate on such tender plants as Lettuces, the check being too great for them. As a preventive, we would suggest first the use of decayed manure free from disease. It is especially necessary to see that the Lettuce crop is not grown on old manure-beds from August, as often during the cold nights of September the mildew appears at the roots and the spores lie dormant till November. Secondly, the use of clean cloches for growing the young seedlings so as to be able to localise to a certain

extent the spreading of the disease by keeping them closed when the plants are attacked. The use of frames tends to spread the disease, as a greater number of plants are housed together. Thirdly, in wet districts, or where the disease has appeared in previous seasons, the place which will be occupied by the seedlings in their winter quarters ought to be watered in September with a solution of copper sulphate one part and water nine parts. Fourthly, the seeds ought to be sown thinly—about 450 to 500 per cloche—and the plants pricked out as early as possible to prevent the decay of the leaves. Fifthly, when young seedlings are attacked the spreading of the disease will be checked by spraying them with flowers of sulphur. This will harden the plants and render them useless for a market crop, but the disease will be destroyed. Sixthly, ventilation should be given whenever possible and the mats only used when absolutely needed, thus allowing the plants to receive ample light and so build up a hardy and sturdy growth.

As it was admitted that sulphate of copper destroyed this fungus, we tried an experiment which was very effectual. When the ground was prepared late in September, for the winter quarter of the young seedlings of Lettuce, we sowed $\frac{1}{2}$ lb. of sulphate of copper in the powdery state for a full-sized bed (65ft. long by 4ft. 6in.). A dressing of well decayed manure was placed, as it is usually done, afterwards. The season 1911-12 was exceedingly wet, and the rainfall was about 5in. in October, 7in. in November and 8in. in December. The plants were slower than usual in their new growth, but were later on as good as desired, and no trace of mildew was apparent except under three bell glasses of Lettuce Little Gott towards the 20th of

November; over these was spread some more sulphate of copper; on December 28th five cloches of Cos Lettuce were also noted as having the disease and were treated in a similar manner. The plants attacked were burnt by the sulphate of copper, but the mildew disappeared and our losses out of 75,000 plants grown were exactly 160. No mildew was seen afterwards when the lettuces were forced on the hot-beds. The disease was very prevalent in the season 1910-11.

“ La Nhuile.”

This is a disease appearing either on the stems or the petiole, or on the stalk of the fruits of Melons and Cucumbers. The part attacked decays through and the plant has to be cut back under the attacked part. Conditions favourable to attack is a brisk change in the temperature, especially from April till June. The only remedy we have found suitable was to scrape the parts attacked till the wound was clean, and then to cover it with lime-sulphur in the powdered state. The disease only appears in very wet summers or where plants do not receive proper attention. Melons must be kept in constant activity by means of an even temperature obtained by spreading the mats at nights, judicious ventilation, and closing the lights before a storm.

Another predisposing cause of the disease is a bad condition of the lights, which is responsible for “drip.” It is for this reason that French gardeners have $3\frac{1}{2}$ panes of glass in a row, as this brings the centre of the light in the middle of the second pane from the top. It also explains why the lights are puttied on the top, so as to shed the rain on to the

glass instead of allowing it to penetrate between the glass and the sash-bars. La Nhuile is of bacterial origin, and no specific name has been assigned to it.

Melon Collar-Rot (*Hypochnus cucumeris*).

As the name suggests, this disease occurs round the collar of the plants. It is prevalent on heavy land, and when, as is often the case, the stump of the stem after the first pruning splits. When the soil placed in the frames is of a heavy nature it ought to be higher in the centre where the plants are set; this prevents, as it were, any undue moisture coming into actual contact with the collar—a condition favourable to the development of the disease.

In the chapter on Melons (p. 135) is described a method of preventing the splitting of the stem—a detail very little known in gardens, yet very efficient.

The collar must receive abundant light by removing any growth or leaf which may shade it. Watering must be carefully done to avoid wetting the collar. When, however, the rot appears, the attacked part should be scraped with a knife till every sign of decay is removed and the bare part gently rubbed with lime-sulphur. This disease is easily stopped when seen in the early stage.

Cauliflower Black Rot or Black Leg (*Pseudomonas campestris*).

This appears in the spring sowings of Cauliflowers. The stem on a certain spot assumes a dark colour; the plants remain healthy and thrive well for two or three months, by which time the stem is eaten through. The first thing to be done is to examine the plants carefully and to eliminate all doubtful specimens.

Another precaution is to prick out all Cauliflowers sown before the 20th of March in a nursery-bed, in order to prevent overcrowding, which is one of the chief predisposing causes. The early sowings must be made very thinly and with very little bottom-heat; ventilation must be given freely whenever possible.

Celery Leaf-Scorch (*Cercospora apii*).

The quick growth of this vegetable on the old manure-bed renders it practically immune from this dreaded disease, yet it is not uncommon to see vestiges of it when the plants are in their nursery quarters, especially when such varieties as Golden Chemin, Pascal and American White are grown. The disease manifests itself by means of small yellow spots on the foliage, which increase in size and coalesce, and the plants have the appearance of being scorched or scalded. When transplanting the plants in their final quarters, all damaged leaves should be carefully removed and the stem and clean leaves dipped in a solution of copper sulphate, 1 part; water, 100 parts. The Long Winter Green Variety, though not so early, is very free from the disease.

Slugs.

These cause great havoc among the seedlings of Lettuces from the time of pricking-off till early in December, when the plants are too big for their unwelcome attention. Soot and lime have been tried without success, as at that time of the year they soon get slack and are injurious to the Lettuces. The only remedy is a constant hunt at dawn every morning, when they will be found in great numbers in the cloches. It is admittedly a slow process, but the only

one that can with safety be recommended. A point worth mentioning is that Slugs do more damage to Cos than to the Cabbage Lettuces like Little Gott, while as for the variety Passion, we have seen it for seasons quite immune from their attacks. Slugs are most troublesome when the beds are made near a hedge.

Turnip Fly.

It is well known that this "fly" (in reality a beetle) will destroy sowing after sowing of Turnips. A remedy is to keep the bed constantly damp till the plants have developed their

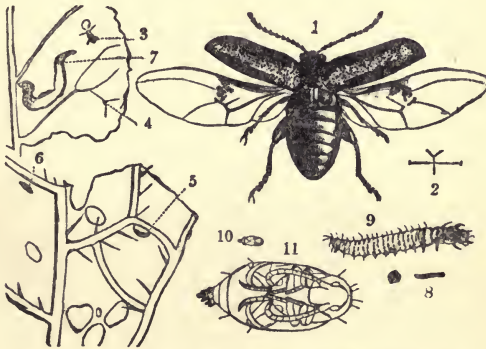

Fig. 27. Turnip Fly (*Phyllotreta nemorum*).

1, Beetle, much magnified; 2, Length and wing expanse; 3, Insect, natural size; 4, 5, Egg, natural size and magnified; 6, 7, Tissue and cuticle eaten away by Larva; 8, 9, Larva, natural size and magnified; 10, 11, Pupa, natural size and magnified.

(By permission of the Board of Agriculture.)

first leaf, or to sow a batch in dull weather, as the germination of the seeds being very rapid the plants will be free from their attacks. When this insect appears in the batch sown on hotbeds in March, a sprinkling of dry road-sweepings or finely sifted ashes stops them sufficiently to allow the plants to progress.

Aphides.

Green or Black Fly (species of *Aphis*) are very little seen in a French garden, as the plants receive frequent waterings; but when they appear among Melons and Cucumbers a fine spraying of nicotine, one part diluted in one hundred parts of water, very often stops it. Aphides are troublesome among fully-grown Cos Lettuces in May and June, and will render a whole batch unmarketable. They are especially prevalent when the plants are grown too long under glass without shade. When noticed before the head is fully formed a watering at a high pressure or a heavy rain will wash it off.

Celery Fly.

The larva of this Fly mines the leaves, and feeds upon the soft juicy substance. It appears when the



Fig. 28. Celery Fly (*Tephritis onopordinis*).

1, Fly, magnified; 2, Larva, magnified; 3, Pupa, natural size.

(By permission of the Board of Agriculture.)

young plants are pricked out in the nursery bed and before the final transplanting. The attacked part must be carefully removed and burnt. As a preventive, the plants may be sprayed once a week, at night-time only, with the following solution: Paraffin, one-eighth of a pint; soft soap, $\frac{1}{2}$ lb.; water, 3 galls.

INDEX.

INDEX.

A

- Agaricus campestris*, 152, 165,
- Animal pests, 177
- Annuals, cultivation of, 6
 - dicocious, 174
 - hermaphrodite, 171, 175
 - monoecious, 175
 - seeds, 170
- Antiquity of intensive culture,
 - 5
- Aphides, 184
- Appliances, 34
- April work, 95
- Area of French garden, 16
- August work, 48

B

- Basket-loading stand, 38
- Baskets, 37
- Beans, French, 54, 59, 65, 69, 101,
 - 112, 118
- Beds, 19
 - Melon, 136, 137
 - size of, 9
- Bench, carpenter's, 41
- Biennials, hermaphrodite, 174
 - seeds, 170
- Black fly, 184
- Black Leg, cauliflower, 181.
- Black Rot of cauliflower, 181

- Black soil, 26
- Buildings, 41

C

- Cabbages, 53, 58, 64, 69, 86, 92,
 - 101, 111
- Calendar of operations, 48-129
- Cans, watering, 36
 - watering with, *Plate* facing
 - p. 36
- Cantaloup Melon, 131
- Cardoons, 55, 60, 65, 70, 93,
 - 100, 109, 117, 126
- Carrier for cloches, 39
- Carrots, 51, 57, 63, 72, 79, 85,
 - 90, 98, 106, 115, 124
- Cart-shed, 41
- Cauliflower Black Leg, 181
 - Black Rot, 181
- Cauliflowers, 52, 58, 64, 69, 79,
 - 81, 91, 98, 106, 116, 125
- Celery, 51, 57, 64, 69, 72, 85,
 - 91, 99, 107, 116, 126
 - diseases, 182
 - Fly, 184
 - Leaf-Scorch, 182
- Cellar culture of mushrooms,
 - 151, 161
 - storage, 41
- Cercospora apii*, 182

Chargeur, 38
 Chicory, 54, 59, 65, 69, 72, 112,
 119, 128
 Clips for frames, 42,
 Cloche-beds, making, 29
 Cloche-carrier, 39
 Cloches, buying, 45
 first position of, for forcing
 lettuce, 83
 greenish tint introduced, 6
 pegs, 40, 41
 qualities of, 46
 second position of, for
 forcing lettuce, 96
 stacking, 46
 standard number of, 16
 standard size, 45
 third position of, for forcing
 lettuce, 104
 uses for, 46
 Collar Rot of melons, 181
 Corn salad, 51, 57, 62, 71
 Cost of a French garden, 17
 "Costieres," 19, 77
 Covering melons, 137
 Cow-manure, unsuitability of,
 5
 Cross-fertilising seeds, 170
 Cucumbers, 48, 52, 58, 146
 cultural details, 146
 diseases, 148
 final planting, 146
 insect pests, 148
 potting, 146
 pruning, 147
 seed-sowing, 146
 stopping, 146
 thinning, 147
 varieties, 146
 ventilation, 147
 watering, 147

D

December work, 71
 Dibbers, 36
 Dioxious annuals, 170, 174
 Diseases, 177
 celery, 182
 mushroom, 165
 Drawbacks to intensive culture,
 24

E

Early Black Rock Melon, 131
 Early history, 5
 Economics, the, of French gar-
 dening, 17
 Employees' syndicates, 7
 Employers' syndicates, 7
 Endive, 49, 56, 61, 71, 84, 90,
 97, 105, 115, 124
 English *v.* French produce, 3
 Even growth, importance of, 11
 Expenses of a French garden, 17

F

"Fairy Rings," 152
 Farnorth French garden,
Frontispiece
 February work, 81
 Fog and damp, evils of, 19
 Forcing Cos lettuce, first posi-
 tion of cloches, 83
 second position of cloches,
 96
 third position of cloches,
 104
 Forks, 35, 36
 Frame culture of mushrooms,
 164
 Frames, 42,
 clips for, 42
 lights for, 42, 43, 44
 mushroom, 161
 positioning, 29
 Frank spawn, 153
 French beans, 54, 59, 65, 69,
 101, 112, 118
 French garden, appliances, 34
 area of, 16
 beds, 19
 busiest time for, 12
 calendar of operations, 48-
 129
 cloches, 46
 cost, 17
 economies, 17
 expenses, 17
 ground for, 18
 hotbeds, 20, 27
 initial cost, 15

French Garden (*cont.*).

- irrigation, 16, 20
- levels, 19
- manuring, 20
- mats, 46, 47
- paths, 19, 20
- places to avoid, 19
- planning, 15
- roads, 18
- site, 18
- soil, 18
- tools, 34
- watering, 16
- what to grow, 48, 49

G

- Gas-lime, 20
- General work, *See* under the different Months
- Glass for lights, quality of, 44
- Green-fly, 184
- Ground, cost of, 18
 - division of, 19
 - preparation of, 19

H

- Hand-barrow, 38, 39
- Hermaphrodite annuals, 175
 - biennials, 174
 - plants, 170
- Hoes, 34
- Horse-manure, 24
- Hose, watering with, introduced, 32
- Hotbeds, 20, 27
 - laying down, 28
 - manure for, 27
 - marking out, 28
 - period for making, 29
 - soil ridges, position of, 74
 - temperature, 27
 - watering, 29, 32
- Hottes, 37
- Hydrants for watering, 33
- Hypochnus cucumeris*, 181
- Hypomyces pernicius*, 154, 155, 166

I

- Implements, storing, 41
- Intensive cultivation, aim of the system, 1
 - annuals a one-time speciality, 6
 - antiquity of, 5
 - approximate returns from, 4
 - assisting nature, 8
 - backbone of, 3
 - drawbacks in England, 24
 - early history, 5
 - English *v.* French produce, 3
 - expansion of the system, 6
 - governing factors in, 4
 - growth, necessity for constant, 8
 - initial cost, 3
 - intercropping, 3, 8
 - labour-saving systems introduced, 7
 - literature, 5
 - originator of, 5
 - planting system, 9
 - prices, 4
 - size of beds, 9
 - spirit of, 1
 - successful practice of, 3
 - syndicates, 7
 - underlying principles, 3
 - uniformity in, 8
 - women's work, 7
- Intercropping, 8, 13
 - standard rules for, 13
- Irrigation, 16
 - installing, 20

J

- January work, 76
- June work, 114
- July work, 120

L

- Labour-saving systems, 7
- Lamb's lettuce, 51, 57, 62, 71

"La Nhuile," 180
 Laying down hotbeds, 28
 Leaves as manure, 24
 Lettuce, 7, 50, 56, 62, 67, 71,
 76, 88, 95, 103, 114
 forcing Cos, 83, 96, 104
 Lamb's, 51, 57, 62, 71
 mildew, 177, 178
 Levels, obtaining, 19
 Lights, 42, 43,
 glass for, 44
 mortising, 45
 position of when starting
 hotbeds, 74
 standard number of, 16

M

Manure, 5, 20, 23
 cow, 5
 horse, 24
 hotbed, 27
 leaves as, 24
 mushroom, 159
 outlay for, 25
 pig, 5
 preparation of, for mush-
 room growing, 160
 qualities used in hotbeds, 28
 slacking, 20
 Maraichers, 5, 34
 district, radius of, 6
 guild, 5
 March work, 88
 Marketing mushrooms, 167
 Marking out hotbeds, 28
 Mats, 46
 May work, 163
 Melons, 7, 48, 52, 57, 87, 92,
 100, 108, 117, 128
 beds for, 136, 137
 choosing the fruits, 143
 Collar-rot, 181
 covering, 137
 culture of, 130-145
 diseases, 145, 181
 final planting, 135
 first pruning, 134
 fourth pruning, 143
 importance of crop, 130
 picking, 144
 potting, 133

Melons (*cont.*).

second pruning, 140, 141
 seed-sowing, 131
 shading, 138
 stem-splitting, prevention of
 135
 third pruning, 141, 142
 varieties, 130, 131
 Mildew, lettuce, 177
Monilia fomicola, 158, 165
 Monœcious annuals, 170, 175
 Mortising lights, method of, 45
 Motor for watering, 33
 Mushrooms, 151
 arranging the manure,
Plate facing p. 160
 cellars for, 150, 151, 161
 covering ridges, 163
 culture, 151, 167
 diseases, 154, 158, 165
 frames for, 161 164
 fungus, 155
 manure for, 159
 marketing, 167
 open-air culture, 165
 packing, 167
 picking, 167
 preparation of manure, 160
 preparing spawn, *Plate*
 facing p. 154
 quarries, 161
 rejuvenating spawn, 157
 sorting, 167
 spawn, 152
 spawning the beds, *Plate*
 facing p. 162
 spores, 156
 strains, 153
 watering the ridge-beds,
Plate facing p. 164
 Mycelium, selecting, 156

N

Nature, assisting, 8
 November work, 67

O

October work, 61
 Onions, 49, 55, 61, 90, 97

Open-air culture of mushrooms, 165
 Open work, planting beds in, 122

P

Packing, 16
 melons, 144
 mushrooms, 167
 uniformity in, 10
 Paths, 19, 20
 Pegs, cloche, 40, 41
Peronospora ganglioniformis, 177
 Pests, animal, 177
 vegetable, 177
Phyllotreta nemorum, 183
 Picking melons, 144
 mushrooms, 167
 Pig manure, unsuitability of, 5
 Planning a French garden, 15
 Plan of Tiptree French garden, 21
 "Plantes Potagères," quoted, 169
 Planting, system of, 9
Pleurotus rutilus, 158
 Preparing manure for mushrooms, 160
 Prescott Melon, 131
 Prices, 4
 Principles of intensive cultivation, 8
 Pruning cucumbers, 147
 melons, 134, 135, 140, 141, 142, 143
Pseudomonas campestris 181
 Pump for watering, 32

Q

Quarries, mushroom, 161
 Quintime, La, quoted, 5, 45

R

Radishes, 7, 78, 86, 98
 Rakes, 35
 Reel, 39

Rejuvenating spawn, 157
 Returns, approximate, 4
 Ridges, mushroom, watering, 163
 spawning, 162
 Roads, 18
 Rock Melon, 131
 Rules, Standard, for intercropping, 13

S

Saprophytes, 152
 Seed saving, 168, 170
 Seeds, annual, 170
 biennial, 170
 cross-fertilising, 170
 vitality of, 169
 weight of, 169
 September work, 55
 Serres, Oliver de, quoted, 5
 Shading melons, 137
 Shovels, 34, 35
 Simon, G. E., quoted, 1.
 Site, choosing, 18
 Slugs, 182
 Soil, 18
 black, 26
 for hotbeds, 74
 Sorting mushrooms, 167
 Spades, 34
 Spawn, frank, 153
 gathering, 158
 rejuvenating, 157
 virgin, 152
 Spawning mushroom ridges, 162
 Spinach, 53, 58
 Spores, mushroom, sowing, 156
 Stable 41
 Stacking manure, 20
 Stand, basket-loading, 38
 Stem-splitting in melons, 135
 Stocks, 6
 Stopping cucumbers, 146
 Storage of implements, 41
 Strawberries, 54, 59, 65, 70, 79, 87, 93, 102, 119, 128
 Swan-neck and hydrant *Plate* facing p. 36
 Symbiosis, 152
 Syndicates, employees', 7
 employers' 7

T

Temperature of hotbeds, 27
Tephritis onopordinis, 184
 Thinning cucumbers, 147
 Tiptree French garden, plan of,
 21
 Tomatoes, 94, 101, 110, 118, 127
 Tools, 34
 Turnip Fly, 183
 Turnips, 7, 94, 109, 118

U

Uniformity, necessity for, 9

V

Vaporite, 20
 Vegetable pests, 177

Ville, George, quoted, 2
 Virgin spawn, 152
 Vitality of seeds, 169

W

Washing-tanks, 41
 Watering, 16, 32,
 cans for, 36
 cucumbers, 147
 hose for, 32
 hotbeds, 29
 hydrants for, 33
 motor for, 33
 mushroom ridges, 163
 pump for, 32
 with cans, *Plate facing p. 36*
 Weight of seeds, 169
 Women's work, 7

Catalogue

of

Practical Handbooks

Published by

L. Upcott Gill, Bazaar Buildings, Drury Lane, London.

CONTENTS.

- ART:** Brasses. Lace. Old Churches. Heraldry. Painting.
AMUSEMENTS: Cards. Entertaining. Photography.
COLLECTING: Old Furniture. Glass. Coins. Medals. Stamps, &c.
DOG-KEEPING: Training, Management and Diseases of Dogs.
FARMING: Goats. Pigs. Horses. Poultry. Bees.
GARDENING: Orchids. Ferns. Flowers. Fruit. Vegetables.
HANDICRAFTS: Wood-Working. Metal-Working. Various.
NATURAL HISTORY: Reptiles. Birds' Eggs. Butterflies. Moths.
PET-KEEPING: Birds. Rabbits. Cavies. Mice. Cats.
SPORTING: Angling. Shooting. Sailing. Boxing, &c.

Art.

ENGLISH CHURCH BRASSES

FROM THE THIRTEENTH TO THE SEVENTEENTH CENTURY.

A Handbook for Antiquaries, Collectors, and others. With a copious list of Churches containing Brasses. Illustrated with over 200 examples reproduced from Rubbings.

By E. R. SUFFLING, Author of "Epitaphia" (see page 4), &c., &c. Demy 8vo, in cloth gilt, price 10/6, by post 10/10.

A HISTORY OF HAND-MADE LACE.

By MRS. E. NEVILL JACKSON.

Exquisitely Illustrated with over 200 high-class Engravings of Old and Valuable Laces and their application to Dress.

In crown 4to, cloth gilt, price 18/-, by post 18/6. Edition de Luxe, on large paper, containing 12 specimens of Real Lace, handsomely bound in full leather, gilt, price £4/4/-, by post £4/5/-.

OLD ENGLISH CHURCHES.

Their Architecture, Furniture, Decorations, Monuments, Vestments, Plate, &c.
Second and Enlarged Edition.

By GEO. CLINCH, F.G.S. Magnificently Illustrated. In cloth gilt, price 6/6, by post 6/10.

PAINTERS AND THEIR WORKS.

A Dictionary of all the Artists of Repute (not now living) from the Thirteenth Century to the present date, and the market value of their principal works.

New (Second) Edition. In 2 vols., demy 8vo.

[IN THE PRESS.]

Church Festival Decorations.

Being full Directions for Garnishing Churches for Christmas, Easter, Whitsuntide, and Harvest, and Notes on other Feasts and Festivals of the Church.

Second Edition. Re-written and Enlarged by ERNEST R. SUFFLING. Profusely Illustrated.

In cloth gilt, price 2/6, by post 2/9.

All Books are Net.

ART (continued).**Heraldry for Amateurs.**

A Popular Handbook for the uninitiated in Matters Heraldic. Including concise Directions regarding the Tracing of Pedigrees.

By J. S. MILBOURNE. Profusely Illustrated. *In cloth, price 3/6, by post 3/9.*

Decorative Painting.

A Practical Handbook on Painting and Etching upon Textiles, Pottery, Porcelain, Paper, Vellum, Leather, Glass, Wood, Stone, Metals, and Plaster, for the Decoration of our Homes.

By B. C. SAWARD. *In cloth gilt, price 3/6, by post 3/10.*

Print Restoration and Picture Cleaning. An excellent and practical Book. *See page 4.*

Adjusting and Repairing Violins, 'Cellos, &c. *See page 11.*

Amusements.**Cards.****NEW GAMES OF PATIENCE.**

Describing and Illustrating Forty-five of the Newest and Best Games not included in "Games of Patience."

And by the same Author, Miss M. WHITMORE JONES. *A handsome volume, in demy 8vo, cloth gilt, price 3/6, by post 3/9.*

Games of Patience.

For One or More Players. How to Play 173 different Games of Patience.

By M. WHITMORE JONES. Illustrated. Series I., 39 games; Series II., 34 games; Series III., 33 games; Series IV., 37 games; Series V., 30 games. *Each, in paper, 1/-, by post 1/2. The five bound together, in cloth gilt, price 6/-, by post 6/4. In full leather, solid gilt edges, price 10/6, by post 10/11.*

Bridge:

ITS WHYS AND WHEREFORES.

The Game Taught by Reason instead of by Rule, on the same popular lines as "Scientific Whist" and "Solo Whist."

And by the same Author, C. J. MELROSE. With Illustrative Hands in Colours. Third Edition. *In cloth gilt, price 3/6, by post 3/10.*

Solo Whist:

ITS WHYS AND WHEREFORES.

A Progressive and Clear Method of Explanation and Illustration of the Game and how to play it successfully. With Illustrative Hands printed in Colours.

By C. J. MELROSE. *In cloth gilt, price 3/6, by post 3/10; in half-leather, gilt top, price 5/6, by post, 6/-.*

Scientific Whist:

ITS WHYS AND WHEREFORES.

The Reader being taught by Reason rather than by arbitrary Rules. With Illustrative Hands printed in Colours.

By C. J. MELROSE. *In cloth gilt, price 3/6, by post 3/10; in half leather, gilt top, 5/6, by post 5/10.*

Entertaining.**Book of Conjuring and Card Tricks.**

By PROFESSOR R. KUNARD.

A Practical Guide to Drawing-room and Stage Magic for Amateurs, with an Exposure of Tricks as practised by Card Sharpers and Swindlers. Fully Illustrated.

Cloth gilt, price 5/-, by post 5/4.

Also in two parts, each in stiff boards price 2/6, by post 2/9:

Book of Modern Conjuring.

Book of Card Tricks.

All Books are Net.

AMUSEMENTS—Entertaining (continued).**MAGICIANS' TRICKS:**

HOW THEY ARE DONE.

A practical book on Tricks with Cards, Coins, Balls and Eggs, Handkerchiefs, &c., with a number of Miscellaneous Tricks. BY HENRY HATTON and ADRIAN PLATE.
In cloth, price 4/6, by post 4/9.

Tricks that Anyone Can Do.

A Collection of Interesting and Amusing Tricks not requiring a knowledge of "sleights" nor elaborate apparatus. BY MORLEY ADAMS. In paper, price 1/-, by post 1/2.

Conjuring for Amateurs.

A Practical Handbook on How to Perform a Number of Amusing Tricks, with Diagrams, where necessary, to explain exactly how the trick is carried out. BY PROFESSOR ELLIS STANYON. In paper, price 1/-, by post 1/2.

Conjuring with Cards.

Being Tricks with Cards, and How to Perform Them. BY PROFESSOR ELLIS STANYON Illustrated. In paper, price 1/-, by post 1/2.

Fortune Telling by Cards.

Describing and Illustrating the Methods by which the would-be occult tells Fortunes by Cards. BY I. B. PRANGLEY. Illustrated. In paper, price 1/-, by post 1/2.

Modern Palmistry.

An Explanation of the Principles of Palmistry as practised to-day. BY I. OXFORD, Author of "Life Studies in Palmistry." Numerous Original Illustrations by L. WILKINS. Cheap Edition. In paper, price 1/-, by post 1/2.

Character Indicated by Handwriting.

With Illustrations in Support of the Theories advanced, taken from Autograph Letters of Statesmen, Lawyers, Soldiers, Ecclesiastics, Authors, Poets, Musicians, Actors, and other persons. Second Edition.

BY R. BAUGHAN. In cloth gilt, price 2/6, by post 2/9.

Practical Ventriloquism

A thoroughly reliable Guide to the Art of Voice Throwing and Vocal Mimicry, Vocal Instrumentation, Ventriloquial Figures, Entertaining, &c. BY ROBERT GANTHONY. Numerous Illustrations. Cheap Edition. In paper, price 1/-, by post 1/2.

Bunkum Entertainments.

A Collection of Original Laughable Skits on Conjuring, Physiognomy, Juggling, Performing Fleas, Waxworks, Phrenology, Second Sight, Ventriloquism, Spiritualism, &c., to which are added Humorous Sketches and Drawing-room Comedies.

BY ROBERT GANTHONY. Illustrated. In cloth, price 2/6, by post 2/9.

Photography.**Photo Printing.**

A Practical Guide, dealing with the leading kinds of P.O.P., Bromide, Platinotype, Carbon, Self-Toning, and Gas-Light Papers. BY HECTOR MACLEAN, F.R.P.S. Second Edition. Illustrated. In paper, price 1/-, by post 1/2.

Modern Photography for Amateurs.

A Practical Handbook for all Photographers except those advanced in the Art. New (Sixth) Edition. Entirely Revised and brought up to date by C. WELBORNE PIPER. In paper price 1/-, by post 1/2.

All Books are Net.

Collecting.

OLD ENGLISH FURNITURE

OF THE 16th, 17th, AND 18th CENTURIES. A Complete Guide to Connoisseurs and Collectors of Old English Furniture.

By G. OWEN WHEELER. Beautifully Illustrated from Photographs of Representative Pieces taken from the Collections of the Author and others. Second Edition, thoroughly Revised and Enlarged, with additional Illustrations. *In cloth gilt, gilt top, price 10/6, by post 11/-.*

EARLY ENGLISH GLASS

OF THE 16th, 17th, AND 18th CENTURIES. A Handbook for the Collector.

By DAISY WILMER. Splendidly Illustrated from Photographs of Representative Pieces taken from the Collections of the Author and others. Second Edition, with additional illustrations, and a record of Auction Prices for typical pieces. *In cloth gilt, gilt top, price 6/6, by post 6/9.*

ENGLISH POTTERY AND PORCELAIN.

A Guide for Collectors. Handsomely Illustrated with Engravings of Specimen Pieces and the Marks used by the different Makers. With some account of the latest values realised.

By the REV. E. A. DOWNMAN and AUBREY GUNN. Fifth Edition, Revised and Enlarged. *In cloth gilt, price 6/6, by post 6/10.*

THE COINS OF GREAT BRITAIN AND IRELAND.

In Gold, Silver, and Copper, from the earliest period to 1905, with their value, By the late COLONEL W. STEWART THORBURN. Fourth Edition, Revised and Enlarged by H. A. GRUEBER, F.S.A. With 42 Plates illustrating over 360 Coins. *In cloth gilt, price 10/6, by post 10/10.*

PRINT RESTORATION AND PICTURE CLEANING.

An Illustrated Practical Guide to the Restoration of all kinds of Prints. Together with Chapters on Cleaning Water-Colours; Print "Fakes" and their Detection; Anomalies in Print Values; Prints to Collect, and other allied subjects.

By MAURICE J. GUNN. *In demy 8vo, cloth gilt, price 6/6, by post 6/10.*

AUTOGRAPH COLLECTING.

A Practical Manual for Collectors and Historical Students. The Selection and Arrangement of Autographs, the Detection of Forgeries, &c.; with numerous Facsimiles for Study and Reference, and an extensive Valuation Table of Autographs worth Collecting.

By HENRY T. SCOTT, M.D., L.R.C.P., &c. *In cloth gilt, price 5/-, by post 5/4.*

WAR MEDALS AND DECORATIONS.

Issued to the British Naval and Military Forces since 1588.

A Manual for Collectors. By D. HASTINGS IRWIN. Fourth Edition, thoroughly Revised and Enlarged, bringing the subject up to 1910. *In cloth gilt, price 15/-, by post 15/5.*

EPITAPHIA.

Being a Collection of 1300 Epitaphs, Grave and Gay, Historical and Curious; annotated with Biographical Notes, Anecdotes, and Church Folk-lore. The whole forming a handsome and most interesting volume.

By ERNEST R. SUFFLING, Author of "English Church Brasses" (see page 1), &c. *Demy 8vo, in cloth gilt, price 7/6, by post 7/10.*

A Guide to English Pattern Coins,

In Gold, Silver, Copper, and Pewter, from Edward I. to Victoria, with their Value.

By the REV. G. F. CROWTHER, M.A. Illustrated. *In cloth gilt, price 5/-, by post 5/3.*

All Books are Net.

COLLECTING (continued).**English Antiquities.**

The Collection of Curios of the Palæolithic, Neolithic, Bronze, Iron, Anglo-Saxon, and Mediæval Times, with a concise Dictionary of Terms, &c.

By GEORGE CLINCH, F.G.S., Author of "Old English Churches" (see page 1). Illustrated. *In cloth gilt, price 6/6, by post 6/10.*

Engravings and their Value.

Describing the different types of Engravings and their production. With a dictionary of all the greatest Engravers and the more important of their works, with Prices obtained at Auction.

By J. H. SLATER. New (fourth) Edition, entirely revised. Illustrated with Plates. Demy 8vo, in one volume. [IN THE PRESS.]

Illustrated Sporting Books

And Their Values. Dealing with English Illustrated Works of a Sporting and Racing Character, and Prints relating to Sports of the Field. A very valuable book to all Owners or Collectors of old Sporting Books or Prints. Many a valuable old print has been thrown away for want of just such information as this book gives.

By J. H. SLATER, Author of "Library Manual," "Engravings and Their Value," &c. *In cloth gilt, price 5/-, by post 5/4.*

Postage Stamps and their Collection.

A Practical Handbook for Collectors of Postal Stamps, Envelopes, and Cards.

By OLIVER FIRTH, Member of the Philatelic Societies of London, Leeds, and Bradford. Profusely Illustrated. *In cloth gilt, price 2/6, by post 2/10.*

In connection with this book we have arranged to supply the Benham Stamp Perforation Gauges. These Gauges, for measuring perforations of stamps, are made in brass, and can be carried in the waistcoat pocket. *Price 1/-, by post 1/1.*

Dictionary of Philatelic Terms.

Explaining the various Technical Words and Phrases uses in Philately, the Signification of Surcharges, Variations of Paper, Methods of Printing, Coinages represented by Face Values of the Stamps, and other matters of practical value and interest.

In foolscap 8vo, cloth gilt, price 1/6, by post 1/8.

The History of the Early Postmarks of the British Isles.

From their Introduction down to 1840, with Special Remarks on and Reference to the Sections of the Postal Service to which they particularly applied.

Compiled chiefly from Official Records by JOHN G. HENDY, Curator of the Record Room General Post Office. Illustrated. *In cloth, price 3/6, by post 3/9.*

See also books mentioned under "ART" on page 1.

Dog-Keeping.**BREAKING AND TRAINING DOGS.**

Being Concise Directions for the Proper Education of Dogs, both for the Field and for Companions.

By "PATHFINDER" and HUGH DALZIEL.

Third Edition, Revised and Enlarged by J. MAXTEE (Author of "The Greyhound," "British Terriers," &c.). Completely Illustrated. *In cloth gilt, price 6/6, by post 6/10.*

BRITISH DOGS.

Their Points, Selection, and Show Preparation. Third Edition.

By W. D. DRURY, assisted by eminent Specialists. Beautifully Illustrated with full-page and other engravings of typical dogs. This is the fullest work on the various breeds kept in Britain. *In 1 vol., demy 8vo, cloth gilt, price 12/6, by post 13/-.*

All Books are Net.

DOG-KEEPING (*continued*).**PRACTICAL KENNEL MANAGEMENT.**

A Complete Treatise on the Proper Management of Dogs for the Show Bench, the Field, or as Companions; with a Chapter on Diseases—their Causes and Treatment. A *Companion Volume* to "BRITISH DOGS." By W. D. DRURY, assisted by well-known Specialists. Illustrated. *In cloth gilt, price 10/6, by post 11/-.*

BRITISH TERRIERS:

Their Breeding, Management and Training for Show or Work.

By J. MAXTEE, Author of "Popular Dog-Keeping," &c. Thoroughly Illustrated. *In cloth gilt, price 3/-, by post, 3/6.* Also in two parts, as follow:

English and Welsh Terriers. Describing in Detail the Various Breeds, their Uses, their Points, and Show Preparation. Being Part I. of "British Terriers." *In paper, price 1/-, by post 1/2.*

Scotch and Irish Terriers. Their History, Breeding, and Management; with Special Sections on Housing, Training, and the Minor Diseases of Terriers in general. Being Part II. of "British Terriers." *In paper, price 1/-, by post 1/2.*

Diseases of Dogs.

Their Causes, Symptoms, and Treatment; Modes of Administering Medicines; Treatment in cases of Poisoning, &c. For the use of Amateurs.

By HUGH DALZIEL. Fourth Edition. Entirely Re-written and brought up to date by ALEX. C. PIESSE, M.R.C.V.S. *In paper, price 1/-, by post 1/2; in cloth gilt, price 2/-, by post 2/6.*

Popular Dog-Keeping.

Being a Handy Guide to the General Management and Training of all Kinds of Dogs for Companions and Pets. Third Edition. By J. MAXTEE. Illustrated. *In paper, price 1/-, by post 1/2.*

The Fox Terrier,

Its History, Points, Breeding, Rearing, Preparing for Exhibition. By HUGH DALZIEL. Second Edition, Revised and brought up to date by J. MAXTEE (Author of "Popular Dog-Keeping"). Fully Illustrated. *In paper, price 1/-, by post 1/2.*

The Collie,

As a Show Dog, Companion, and Worker. By HUGH DALZIEL. Revised by J. MAXTEE, Author of "Popular Dog-Keeping," &c., &c. Third Edition. Illustrated. *In paper, price 1/-, by post 1/2.*

The Greyhound:

Its History, Points, Breeding, Rearing, Training, and Running. By HUGH DALZIEL. Second Edition, Revised and brought up to date by J. MAXTEE, assisted by THEODORE BEAUMONT RIXON. Illustrated. *In paper, price 1/-, by post 1/2.*

The Whippet, or Race-Dog:

How to Breed, Rear, Train, Race, and Exhibit the Whippet, the Management of Race Meetings, and Original Plans of Courses. By FREEMAN LLOYD. Second Edition. Illustrated. *In paper, price 1/-, by post 1/2.*

First-Aid to Dogs,

And Kennel Emergencies;

With Valuable Chapters on the Mother and Puppies, &c. By Surgeon W. GORDON STABLES, R.N., M.D., &c. Illustrated. *In cloth, price 1/6, by post 1/9.*

All Books are Net

Farming.

THE BOOK OF THE GOAT.

Containing full particulars of the Various Breeds of Goats, and their Profitable Management.

By H. S. HOLMES PEGLER (Hon. Secretary of British Goat Society).
Fourth Edition, Revised and Enlarged. Well Illustrated. *In cloth gilt, price 6/-, by post 6/4.*

THE BOOK OF THE PIG.

The Selection, Breeding, Feeding, and Management of the Pig; The Treatment of its Diseases; the Curing and Preserving of Hams, Bacon, and other Pork Foods; and other information appertaining to Pork-Farming.

Fully Illustrated with Portraits of Prize Pigs, Plans of Model Piggeries, &c.
By PROF. JAMES LONG. Second Edition, Revised. *In large post 8vo, cloth gilt, price 6/6, by post 6/10.*

PROFITABLE PIG BREEDING AND FEEDING.

The Successful Breeding, Rearing, Fattening, and Management of Pigs for the Market; The Curing of Hams, &c.

By THOMAS ALLEN. With a chapter on Diseases by HAROLD LEENEY, M.R.C.V.S.
In cloth gilt, price 3/6, by post 3/10.

THE PRACTICAL HORSE-KEEPER.

By GEORGE FLEMING, C.B., LL.D., F.R.C.V.S., late principal Veterinary Surgeon to the British Army, and Ex-President of the Royal College of Veterinary Surgeons.
Illustrated with full-page Plates. *In cloth gilt, price 3/6, by post 3/10.*

MODERN DAIRY FARMING.

A Practical Handbook on the Management of the Milch Cow and the Profitable Utilisation of Milk, for Students, Tenant Farmers, and Amateurs.

By H. L. PUXLEY. Illustrated. *In cloth gilt, price 3/6, by post 3/10.*

POULTRY FOR PRIZES AND PROFIT.

A Complete and Practical Guide to the Breeding and Management of Domestic Fowls for Exhibition and General Purposes. Magnificently Illustrated.

By PROFESSOR JAMES LONG. Third Edition, Revised and Enlarged by W. M. ELKINGTON.
In cloth gilt, price 6/-, by post 6/4. Also in Divisions as follow:

Poultry for Prizes.

A Standard Work as to the Points of the various Breeds and the Management of Exhibition Poultry. Profusely Illustrated. *In cloth gilt, price 3/-, by post 3/3.*

Poultry for Profit.

The Practical Management of Utility Poultry, with Illustrated Descriptions of the various Breeds. *In cloth gilt, price 3/-, by post 3/3.*

THE SMALLHOLDER'S HANDBOOK.

Dealing concisely but clearly with Farm and Garden Crops, Dairying, Sheep, Pigs, Poultry, Bees, &c., for Profit.

By W. M. ELKINGTON, assisted by Specialists. Fully Illustrated. *In cloth gilt, price 3/6, by post 3/9.*

Goat-Keeping for Amateurs.

Being the Practical Management of Goats for Milking Purposes; with a chapter on Diseases.
New (Second) Edition Illustrated. *In paper, price 1/-, by post 1/2.*

All Books are Net.

FARMING (continued).**Practical Pig-Keeping.**

A Manual for Amateurs, based on Personal Experience in Breeding, Feeding, and Fattening; also in Buying and Selling Pigs at Market Prices. By R. D. GARRATT. Third Edition, Revised. *In paper, price 1/-, by post 1/2.*

Horse Buying and Management.

A Practical Handbook for the Guidance of Amateurs in Buying a Horse, with Instructions as to its after-management. By HENRY E. FAWCUS. Illustrated. *In paper, price 1/-, by post 1/2.*

Horse-Keeping for Amateurs.

A Practical Manual on the Management of Horses, for the guidance of those who keep one or two for their personal use. By FOX RUSSELL. *In paper, price 1/-, by post 1/2; cloth gilt, price 2/-, by post 2/3.*

Diseases of Horses:

Their Causes, Symptoms, and Treatment. For the use of Amateurs. By HUGH DALZIEL. New Edition, revised throughout by A. C. PIESSE, M.R.C.V.S. *In paper, price 1/-, by post 1/2; cloth gilt, price 2/-, by post 2/2.*

Popular Poultry Keeping.

A Practical and Complete Guide to Breeding and Keeping Poultry for Eggs or for the Table. Fourth Edition, with Additional Matter and Illustrations. By W. M. ELKINGTON. *In paper, price 1/-, by post 1/2.*

Incubators and their Management.

The very book for the Amateur who runs, or proposes to run, an Incubator. By J. H. SUTCLIFFE. Sixth Edition, Revised. Illustrated. *In paper, price 1/-, by post 1/2.*

Poultry and Egg Raising at Home.

A Practical Work showing how Eggs and Poultry may be produced for Home Consumption with little expenditure of time or money. By W. M. ELKINGTON. Illustrated. *In paper, price 1/-, by post 1/2.*

Profitable Poultry-Farming.

Describing in Detail the Methods that Give the Best Results, and pointing out the Mistakes to be Avoided. By J. H. SUTCLIFFE. Illustrated. *In paper, price 1/-, by post 1/2.*

Book of Bee-Keeping.

A very Practical and Complete Manual on the Proper Management of Bees, especially written for Beginners and Amateurs who have but a few Hives. By W. B. WEBSTER, First-class Expert, B.B.K.A. Fourth Edition. Fully Illustrated. *In paper, price 1/-, by post 1/2; in cloth, 1/6, by post 1/8.*

Bees and Bee-Keeping.

Scientific and Practical.

By F. R. CHESHIRE, F.L.S., F.R.M.S., Lecturer on Apiculture at South Kensington. *In 2 vols.*
Vol. I., Scientific. A Complete Treatise on the Anatomy and Physiology of the Hive Bee. *In cloth gilt, price 7/6, by post 7/10.*

Vol. II., Practical Management of Bees. An Exhaustive Treatise on Advanced Bee Culture. [Out of Print.]

All Books are Net.

Gardening.

DICTIONARY OF GARDENING.

A Practical Encyclopædia of Horticulture, for Amateurs and Professionals. Illustrated with 3150 Engravings.

Edited by G. NICHOLSON, Curator of the Royal Botanic Gardens, Kew; assisted by Prof. Trail, M.D., Rev. P. W. Myles, B.A., F.L.S., W. Watson, J. Garrett, and other Specialists. In 5 vols., large post 4to. Cloth gilt, price £4, carriage paid £4/1/6.

Also obtainable splendidly bound in half persian; full particulars, with descriptive circular giving price and instalment terms, will be sent on application.

OPEN-AIR GARDENING:

The Culture of Hardy Flowers, Fruit and Vegetables.

Edited by W. D. DRURY, F.E.S. Beautifully Illustrated. In demy 8vo, cloth gilt, price 6/-, by post 6/5.

GREENHOUSE MANAGEMENT FOR AMATEURS.

The Best Greenhouses and Frames and How to Build and Heat them, Illustrated Descriptions of the most suitable Plants, with General and Special Cultural Directions, and all necessary information for the guidance of the Amateur.

By W. J. MAY. Fifth Edition, Revised and Enlarged. Magnificently Illustrated. In large post 8vo, cloth gilt, price 5/-, by post 5/4.

ORCHIDS:

Their Culture and Management.

By W. WATSON, Curator, Royal Botanic Gardens, Kew.

Third Edition, thoroughly Revised and Enlarged, with a List of Hybrids and their Recorded Parentage, and Detailed Cultural Directions, by HENRY J. CHAPMAN, one of the finest growers and judges in the kingdom.

Beautifully Illustrated with 180 Engravings and 20 Coloured Plates. In demy 8vo, cloth gilt extra, price 25/-, by post 25/6.

CHOICE FERNS FOR AMATEURS.

Their Culture and Management in the Open and Under Glass. Abridged from "The Book of Choice Ferns."

By GEO. SCHNEIDER. With numerous Illustrations. In cloth gilt, price 3/6, by post 3/9.

CACTUS CULTURE FOR AMATEURS.

Being Descriptions of the various Cactuses grown in this country; with Full and Practical Instructions for their Successful Cultivation.

By W. WATSON, Assistant Curator of the Royal Botanic Gardens, Kew.

Second Edition. Profusely Illustrated. In cloth gilt, price 5/-, by post 5/4.

ALPINE PLANTS.

A Practical Manual for their Culture.

By W. A. CLARK, F.R.H.S. With a Supplementary Essay on the Small Rock Garden. Second Edition, Revised and Enlarged. In cloth gilt, price 3/6, by post 3/9.

Fruit Culture for Amateurs.

An Illustrated Practical Handbook on the Growing of Fruits in the Open Air, with Directions for dealing with Insect Pests and Fungoid Diseases.

By S. T. WRIGHT. Cheap (Third) Edition, thoroughly revised by W. D. DRURY, F.R.H.S., F.E.S. Illustrated. In paper, price 1/-, by post 1/2.

Grape Growing for Amateurs.

A Thoroughly Practical Book on Successful Vine Culture. By E. MOLYNEUX. Illustrated. In paper, price 1/-, by post 1/2.

Tomato Culture for Amateurs.

A Practical and very Complete Manual on the subject. By B. C. RAVENSCROFT. Third Edition. Illustrated. In paper, price 1/-, by post 1/2.

All Books are Net.

GARDENING(continued).**Hardy Perennials and Old-fashioned Garden Flowers.**

Descriptions, alphabetically arranged, of the most desirable Plants for Borders, Rockeries, and Shrubberies, including Foliage as well as Flowering Plants.

By J. WOOD. Profusely Illustrated. *In cloth gilt, price 3/6, by post 3/10.*

Home Gardening.

A Manual for the Amateur, containing Instructions for the Laying Out, Stocking, Cultivation and Management of Small Gardens—Flower, Fruit, and Vegetable. By W. D. DRURY, F.R.H.S. Second Edition. Illustrated. *In paper, price 1/-, by post 1/2.*

Popular Bulb Culture.

A Practical and Handy Guide to the Successful Cultivation of Bulbous Plants, both in the Open and under Glass. By W. D. DRURY. Third Edition. Thoroughly Revised and Enlarged. Fully Illustrated. *In paper, price 1/-, by post 1/2.*

Roses for Amateurs.

A Practical Guide to the Selection and Cultivation of the best Roses.

By the REV. J. HONYWOOD D'OMBRAIN, late Hon. Sec. Nat. Rose Soc. Third Edition, thoroughly Revised and much Enlarged, with a Chapter on Insects and Fungi injurious to Roses, by W. D. DRURY, F.E.S. Fully and well Illustrated. *In paper, price 1/-, by post 1/2.*

Carnation Culture for Amateurs.

The Culture of Carnations and Picotees of all Classes in the Open Ground and in Pots. By B. C. RAVENSCROFT. Fourth Edition. Illustrated. *In paper, price 1/-, by post 1/2.*

Mushroom Culture for Amateurs.

With Full Directions for Successful Growth in Houses, Sheds, Cellars, and Pots, on Shelves, and Out of Doors, including Pasture Lands. By W. J. MAY. Second Edition, thoroughly revised and with New Illustrations. *In paper, price 1/-, by post 1/2.*

Handicrafts.**Wood-Working.****Cabinet Making for Amateurs.**

Being Clear Directions How to Construct many Useful Articles, such as Brackets, Sideboards, Tables, Cupboards, and other Furniture.

Edited by JOHN P. ARKWRIGHT. Illustrated. *In demy 8vo, cloth, price 2/6, by post 2/9.*

Wood Carving for Amateurs.

Full instructions for producing all the different varieties of Carving.

Second Edition. Edited by D. DENNING. Illustrated. *In paper, price 1/-, by post 1/2.*

Polishes and Stains for Woods.

A Complete Guide to Polishing Woodwork, with Directions for Staining, and Full Information for Making the Stains, Polishes, &c., in the simplest and most satisfactory manner. By DAVID DENNING. *In paper, price 1/-, by post 1/2.*

Marqueterie Wood-Staining for Amateurs.

A Practical Handbook to Marqueterie Wood-Staining and Kindred Arts. By ELIZA TURCK. Profusely Illustrated. *In paper, price 1/-, by post 1/2.*

Picture-Frame Making for Amateurs.

Being Practical Instructions in the Making of various kinds of Frames for Paintings, Drawings, Photographs, and Engravings. By the REV. J. LUKIN. Illustrated. *In paper, price 1/-, by post 1/2.*

All Books are Net.

HANDICRAFTS (continued).**Metal-Working.****Simple Forge Work for Amateurs.**

A Practical Handbook for Beginners in the Blacksmith's Art. By H. J. S. CASSAL. Illustrated. *In paper, price 1/-, by post 1/2.*

Chucks and Chucking.

Being an Account of Chucks New and Old, and of How to Use Them, with a Description of Various Methods of Mounting Work in the Lathe. By H. J. S. CASSAL. Profusely Illustrated. *In paper, price 1/-, by post 1/2.*

Repoussé Work for Amateurs.

Being the art of Ornamenting Thin Metal with Raised Figures. By L. L. HASLOPE. Illustrated. *In paper, price 1/-, by post 1/2.*

Bent Iron Work.

A Practical Manual of Instruction for Amateurs in the Art and Craft of Making and Ornamenting Light Articles in imitation of the beautiful Mediæval and Italian Wrought Iron Work. By F. J. ERSKINE. Illustrated. *In paper, price 1/-, by post 1/2.*

Various.**PRINT RESTORATION AND PICTURE CLEANING.**

An Illustrated Practical Guide to the Restoration of all kinds of Prints. Together with Chapters on Cleaning Water-Colours; Print "Fakes" and their Detection; Anomalies in Print Values, and Prints to Collect.

By MAURICE JAMES GUNN. With 18 Full-page Plates. *In demy 8vo, cloth gilt, price 6/6, by post 6/10*

WORKSHOP MAKESHIFTS.

Being a Collection of Practical Hints and Suggestions, including Directions for the Home Manufacture of Tools from odd pieces of Metal; for the use of Amateur Workers in Wood and Metal.

By H. J. S. CASSAL. Fully Illustrated. *In cloth gilt, price 2/6, by post 2/9.*

Glues and Cements.

A Practical Book on Making and Using Glues, Cements, and Fillings. Invaluable in every Workshop. By H. J. S. CASSAL, Author of "Chucks and Chucking," &c. Illustrated. *In paper, price 1/-, by post 1/2.*

Bookbinding for Amateurs.

Being Descriptions of the various Tools and Appliances Required, and Minute Instructions for their Effective Use.

By W. J. E. CRANE. Illustrated with 156 Engravings. *In cloth gilt, price 2/6, by post 2/9.*

Cane Basket Work.

A Practical Manual on Weaving Useful and Fancy Baskets. By ANNIE FIRTH. Series I. and II. Illustrated. *In cloth gilt, price 1/6, by post 1/8 each.*

Window Ticket Writing.

Containing full Instructions on the Method of Mixing and Using the Various Inks, &c., required, Hints on Stencilling as applied to Ticket Writing, together with Lessons on Glass Writing, Japanning on Tin, &c. Especially written for the use of Learners and Shop Assistants.

By WM. C. SCOTT. Illustrated. *In paper, price 1/-, by post 1/2.*

Adjusting and Repairing Violins, 'Cellos, &c.

A Practical Handbook that should be in the hands of all Players. By A. BROADLEY. Illustrated. *In paper, price 1/-, by post 1/2.*

Model Yachts and Boats.

Their Designing, Making, and Sailing. Illustrated with 118 Designs and Working Diagrams.

By J DU V. GROSVENOR. Cheap Edition. *In cloth gilt, price 2/6, by post 2/9.*

All Books are Net.

Natural History.

BRITISH DRAGONFLIES.

Being an Exhaustive Treatise on our native Odonata; their Collection, Classification, and Preservation.

By W. J. LUCAS, B.A. Very fully Illustrated with 27 Plates, Illustrating 39 Species, Exquisitely printed in Colour, and Numerous Black-and-White Engravings. *In cloth gilt, price 10/6, by post 10/11.*

THE VIVARIUM.

Being a Full Description of the most Interesting Snakes, Lizards, and other Reptiles, and How to Keep Them Satisfactorily in Confinement.

By REV. G. C. BATEMAN. Beautifully Illustrated. *In cloth gilt, price 7/6, by post 7/10.*

BIRDS' EGGS OF THE BRITISH ISLES.

A Comprehensive Guide to the Collector of British Birds' Eggs, with Hints respecting the Preparation of Specimens for the Cabinet.

Collated and compiled by ARTHUR G. BUTLER, Ph.D., F.L.S., F.Z.S., F.E.S., from his larger work, "British Birds, with their Nests and Eggs."

Beautifully Illustrated with 24 full-page plates in colour. *In demy 4to, cloth gilt, price 10/6, by post 10/11.*

PRACTICAL TAXIDERMISTRY.

A Manual of Instruction to the Amateur in Collecting, Preserving, and Setting-up Natural History Specimens of all kinds. With Examples and Working Diagrams.

By MONTAGU BROWNE, F.Z.S., Curator of Leicester Museum. Second Edition. *In cloth gilt, price 7/6, by post 7/10.*

FRESHWATER AQUARIA.

Their Construction, Arrangement, Stocking, and Management.

Second Edition, Revised and Enlarged.

By REV. G. C. BATEMAN, A.K.C. Fully Illustrated. *In cloth gilt, price 3/6, by post 3/10.*

British Lizards.

The Standard Work on the Subject.

Dealing with the Life-History and Distribution of the Lizards of the British Isles.

By GERALD R. LEIGHTON, M.D., F.R.S.E. Copiously Illustrated by Drawings and Photographs from Life, many by DOUGLAS ENGLISH and the Author. *In cloth, price 5/-, by post 5/3.*

The Book of British Butterflies.

A Practical Manual for Collectors and Naturalists.

Splendidly Illustrated throughout with very accurate Engravings of the Caterpillars, Chrysalids, and Butterflies, both upper and under sides, from drawings by the Author or direct from Nature.

By W. J. LUCAS, B.A. *In cloth gilt, price 2/6, by post 2/9.*

Butterfly and Moth Collecting.

Being Practical Hints as to Outfit, most profitable Hunting Grounds, and Best Methods of Capture and Setting, with brief descriptions of many species. Second Edition, revised, re-arranged, and enlarged. Illustrated. *In paper, price 1/-, by post 1/2.*

Book of British Hawk Moths.

A Popular and Practical Manual for all Lepidopterists. Copiously Illustrated in Black and White from the Author's own exquisite Drawings from Nature.

By W. J. LUCAS, B.A. *In cloth gilt, price 3/6, by post 3/9.*

All Books are Net.

Pet-Keeping.

Birds.

THE CANARY BOOK.

The Breeding, Rearing, and Management of all Varieties of Canaries and Canary Mules, and all other matters connected with this Fancy.

By ROBERT L. WALLACE. Third Edition. With Coloured Frontispiece. *In cloth gilt, price 5/-, by post 5/4.* Also in two sections, as follow :

General Management of Canaries.

Cages and Cage-making, Breeding, Managing, Diseases and their Treatment, Pests, &c. Illustrated. *In cloth gilt, price 2/6, by post 2/9.*

Exhibition Canaries.

Full Particulars of all the different Varieties, their Points of Excellence, Preparing Birds for Exhibition, Formation and Management of Canary Societies and Exhibitions. Illustrated. *In cloth gilt, price 2/6, by post 2/9.*

Canary-Keeping for Amateurs.

A Book for the Average Canary-Keeper. Plain and Practical Directions for the Successful Management and Breeding of Canaries as Pets rather than for Exhibition. By DR. W. T. GREENE, F.Z.S. Illustrated. *In paper, price 1/-, by post 1/2.*

British Birds for Cages and Aviaries.

A Handbook on the varieties which may be kept in Confinement. Illustrated. By DR. W. T. GREENE. *In cloth gilt, price 3/6, by post 3/10.*

Favourite Foreign Birds for Cages and Aviaries.

How to Keep them in Health.

By W. T. GREENE, M.A., M.D., F.Z.S., &c. Second Edition. Fully Illustrated. *In cloth gilt, price 2/6, by post 2/9.*

Diseases of Cage Birds :

Their Causes, Symptoms, and Treatment. A handbook for everyone who keeps a bird. By DR. W. T. GREENE, F.Z.S. *In paper, price 1/-, by post 1/2.*

Pigeon-Keeping for Amateurs.

A Complete Guide for the Amateur Breeder of Domestic and Fancy Pigeons. By J. C. LYELL. Illustrated. *In cloth gilt, price 2/-, by post 2/3; in paper, price 1/-, by post 1/2.*

Popular Parrakeets :

How to Keep and Breed Them. By W. T. GREENE, M.D., M.A., F.Z.S., &c. With 8 Full-page Plates. *In paper, price 1/-, by post 1/2.*

The Grey Parrot,

and How to Treat it. By W. T. GREENE, M.D., M.A., F.Z.S., &c. Second Edition. *In paper, price 1/-, by post 1/2.*

Rabbits, &c.

The Management of Rabbits.

Including Hutches, Breeding, Feeding, Diseases and their Treatment, Rabbit Courts, &c. Third Edition. Revised by MEREDITH FRADD. Fully Illustrated. *In paper, price 1/-, by post 1/2.*

All Books are Net.

PET-KEEPING (*continued*).**The Guinea Pig,**

For Food, Fur, and Fancy. Its Varieties and its Management. By C. CUMBERLAND, F.Z.S. Illustrated. *In paper, price 1/-, by post 1/2. In cloth gilt, with coloured frontispiece, price 2/6, by post 2/9.*

Fancy Mice:

Their Varieties, Management, and Breeding. Fourth Edition, with additional matter and Illustrations. *In coloured wrapper representing different varieties, price 1/-, by post 1/2.*

Domestic and Fancy Cats.

A Practical Treatise on their Varieties, Breeding, Management, and Diseases. By JOHN JENNINGS. Second Edition, Revised and Enlarged. Illustrated. *In paper, price 1/-, by post 1/2.*

Pet Monkeys,

And How to Manage Them. By ARTHUR PATTERSON. Illustrated. Second Edition, Revised. *In paper, price 1/-, by post 1/2.*

See also under "DOG-KEEPING" and "NATURAL HISTORY."

Sporting.**Angling.****THE BOOK OF THE ALL-ROUND ANGLER.**

A Comprehensive Treatise on Angling in both Fresh and Salt Water. By JOHN BICKERDYKE. Completely illustrated. New (Third) Edition. *In cloth gilt, price 5/6, by post 5/10.*

Also in Four Divisions as follow:—

Angling for Coarse Fish. Bottom Fishing, according to the Methods in use on the Thames, Trent, Norfolk Broads, and elsewhere. Third Edition, Revised throughout. Illustrated. *In paper, price 1/-, by post 1/2.*

Angling for Pike. The most approved Methods of Fishing for Pike or Jack. New (Third) Edition, Revised. Profusely Illustrated. *In paper, price 1/-, by post 1/2.*

Angling for Game Fish. The Various Methods of Fishing for Salmon; Moorland, Chalk-stream, and Thames Trout; Grayling and Char. Third Edition, Completely revised. Well Illustrated. *In paper, price 1/6, by post 1/9.*

Angling in Salt Water. Sea Fishing with Rod and Line, from the Shore, Piers, Jetties, Rocks, and from Boats; together with Some Account of Hand-lining. New (Third) Edition. Over 50 Engravings. *In paper, price 1/-, by post 1/2.*

PRACTICAL SEA-FISHING.

A Comprehensive Handbook for all Sea Anglers, on the Best Tackle, and most Successful Methods of Sea Angling on our Coasts. By P. L. HASLOPE. Fully Illustrated. *In cloth gilt, price 3/6, by post 3/9.*

THE MODERN ANGLER.

A Practical Handbook on all Kinds of Angling, both Fresh Water and Sea. By "OTTER." Well Illustrated. Third Edition. *In cloth gilt, price 2/6, by post 2/9.*

Sea-Fishing for Amateurs.

A Practical Book on Fishing from Shore, Rocks, or Piers, with a Directory of Fishing Stations on the English and Welsh Coasts. Illustrated by numerous Charts showing the best spots for the various kinds of fish, position of rocks, &c. Second Edition, Revised, Enlarged, and copiously Illustrated. By FRANK HUDSON. *In paper, price 1/-, by post 1/2.*

All Books are Net.

SPORTING (continued).**Sailing, &c.****SAILING TOURS.**

The Yachtsman's Guide to the Cruising Waters of the English and Adjacent Coasts. With Descriptions of every Creek, Harbour, and Roadstead on the Course. With numerous Charts printed in Colours, showing Deep Water, Shoals, and Sands exposed at Low Water, with soundings.

By FRANK COWPER, M.A. *In crown 8vo, cloth gilt.*

Vol. I. The Coasts of Essex and Suffolk, from the Thames to Aldborough. Six Charts. *Price 5/-, by post 5/3.*

Vol. II. The South Coast, from the Nore to the Scilly Isles. Third Edition, Re-written and Revised throughout. Twenty-four Charts. *Price 7/6, by post 7/10.*

Vol. III. The Coast of Brittany, from L'Aberwrach to St. Nazaire, and an Account of the Loire. Twelve Charts. *Price 7/6, by post 7/10.*

Vol. IV. The West Coast, from Land's End to Mull of Galloway, including the East Coast of Ireland. Thirty Charts. *Price 10/6, by post 10/10.*

Vol. V. The Coasts of Scotland and the N.E. of England down to Aldborough. Forty Charts. *Price 10/6, by post 10/10.*

PRACTICAL YACHTING FOR AMATEURS.

A New and Complete Work. The Handling of Fore and Aft Sailing Boats; Sails and Gear; Rules of the Road; Cruising; Racing, &c.

By FRANK COWPER (Author of "Sailing Tours," &c.). Fully Illustrated. *Large post 8vo. In cloth gilt, price 5/-, by post, 5/4.*

A DICTIONARY OF SEA TERMS.

For the use of Yachtsmen, Voyagers, and all who go down to the sea in big or little ships.

By A. ANSTED. Fully Illustrated. *In cloth gilt, price 5/-, by post 5/4.*

PRACTICAL BOAT BUILDING AND SAILING.

Containing Full Instructions for Designing and Building Punts, Skiffs, Canoes, Sailing Boats, &c. Particulars of the most suitable Sailing Boats and Yachts for Amateurs, and Instructions for their Proper Handling. Fully Illustrated with Designs and Working Diagrams.

By ADRIAN NEISON, C.E., DIXON KEMP, A.I.N.A., and G. CHRISTOPHER DAVIES. *In 1 vol., cloth gilt, price 7/6, by post 7/10. Also in two vols. as follow:—*

Practical Boat Building for Amateurs.

The Designing and Building of Punts, Skiffs, Canoes, Sailing Boats, &c.; with Working Diagrams.

By ADRIAN NEISON, C.E. Second Edition, Revised and Enlarged by DIXON KEMP, Author of "A Manual of Yacht and Boat Sailing," &c. *In cloth gilt, price 2/6, by post 2/9.*

Practical Boat Sailing for Amateurs.

The most Suitable Sailing Boats and Yachts for Amateurs and their Proper Handling.

By G. CHRISTOPHER DAVIES. Illustrated with numerous Diagrams, and Plans of Yachts. *In cloth gilt, price 5/-, by post 5/4.*

Shooting, &c.**PRACTICAL GAME PRESERVING.**

Containing the fullest Directions for Rearing and Preserving both Winged and Ground Game, and Destroying Vermin; with other information of Value to the Game Preserver.

By W. CARNEGIE. Illustrated by F. W. FROHAWK, M. F. LYDON, and others. Third Edition. *In cloth gilt, price 7/6, by post 7/11.*

PRACTICAL WILDFOWLING.

A very Complete and Essentially Practical Guide to the Art of the Fowler. With Descriptions of the various Birds usually met with.

Second Edition, Revised and Greatly Enlarged. By W. T. FALLON. Profusely Illustrated. *In cloth gilt, price 6/-, by post 6/4.*

All Books are Net.

SPORTING—Shooting, &c. (continued).

Practical Trapping.

Being some Papers on Traps and Trapping for Vermin, with a Chapter on General Trapping and Snaring Birds, and Catching Rats, Cats, Otters, &c. By W. CARNEGIE. Third Edition, Revised and Enlarged. Illustrated. *In paper, price 1/-, by post 1/2.*

Ferrets and Ferreting.

Containing Instructions for the Breeding, Managing, Training, and Working of Ferrets. Fourth Edition. Revised and Enlarged. Illustrated. *In paper, price 1/-, by post 1/2.*

The Complete Air-Gunner.

A Sound Practical Book on Home Culture in Rifle Shooting by means of the Air-Gun. By R. B. TOWNSHEND, Member of the "Legion of Frontiersmen." Illustrated with Diagrams and 16 Plates. *In paper, price 1/-, by post 1/2.*

Various.

THE BOOK OF THE CARAVAN.

A Complete Handbook to the Pastime of Caravaning.

By L. C. R. CAMERON. Profusely Illustrated. *In cloth, foolscap 8vo, price 3/6, by post 3/9.*

Motorist's and Cyclist's Route Map

of England and Wales. Shows clearly all the Main and Most of the Cross Roads, Railroads, and the Distances between the Chief Towns, as well as the Mileage from London. In addition to this, Routes of *Thirty of the Most Interesting Tours* are printed in red. Fourth Edition. The map is printed on specially prepared vellum paper, and is the fullest, handiest, and best up-to-date tourist's map in the market. *In cloth, price 1/-, by post 1/2.*

Lessons in Lawn Tennis.

A New Method of Study and Practice for acquiring a Good and Sound Style of Play. With Exercises. By EUSTACE H. MILES. Third and Revised Edition. Illustrated. *In paper, price 1/-, by post 1/2.*

Skating Card Booklet.

An Easy Method of Learning Figure Skating, as the Booklet can be used on the Ice. *In paper, price 1/-, by post 1/1.*

Swimming for Women and Girls.

A Handbook of Practical Instruction. By COLIN HAMILTON. With Special Chapters upon Costume and Training by a Lady Champion Swimmer. Fully Illustrated by Unique and Specially-taken Photographs. *In paper, price 1/-, by post 1/2.*

Boxing at a Glance.

A Practical Handbook showing the Chief Blows, Counters, and Guards, with unique Bird's-Eye-View Illustrations. By J. MURRAY WRIGHT. *In paper, price 1/-, by post 1/2.*

Jiu-Jitsu

And other Methods of Self-Defence. Describing and Illustrating the Japanese Art of Jiu-Jitsu, with a section specially adapted to Ladies, together with a description of a number of Tricks of Self-Defence well within the capacity of anyone. By PERCY LONGHURST, Author of "Wrestling in the Catch-hold and Græco-Roman Styles." Profusely Illustrated. *In paper, price 1/-, by post 1/2.*

Wrestling.

A Practical Handbook upon the Catch-hold and Græco-Roman Styles of Wrestling. A splendid system of Athletic Training. By PERCY LONGHURST, winner in the Light-weight Competition, G.G.S., 1899; Author of "Jiu-Jitsu and other Methods of Self-Defence." Profusely Illustrated. *In paper, price 1/-, by post 1/2.*

All Books are Net.

THIS BOOK IS DUE ON THE LAST DATE
STAMPED BELOW

AN INITIAL FINE OF 25 CENTS

WILL BE ASSESSED FOR FAILURE TO RETURN
THIS BOOK ON THE DATE DUE. THE PENALTY
WILL INCREASE TO 50 CENTS ON THE FOURTH
DAY AND TO \$1.00 ON THE SEVENTH DAY
OVERDUE.

JUN 5 1941

AUG 9 1875 58

REC. CIR. OCT 8 '78

FACULTY LOAN DUE

MAY 23 1890

RECEIVED

MAY 23 1989 - 10 PM

EDUC-PSYCH. LIBRARY

SENT ON ILL

JAN 08 1996

U. C. BERKELEY

ques
140 a
hu

YC 61975

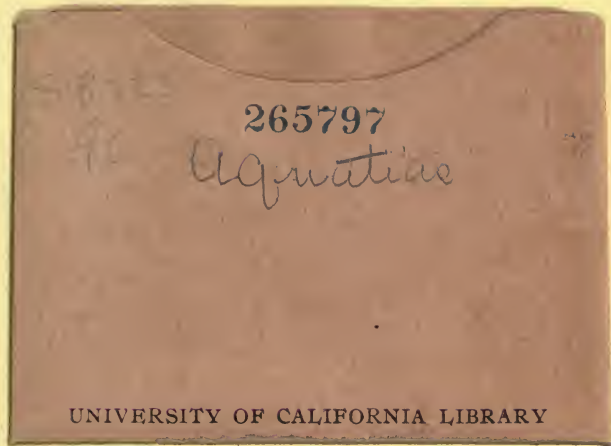

UNIVERSITY OF CALIFORNIA LIBRARY

